

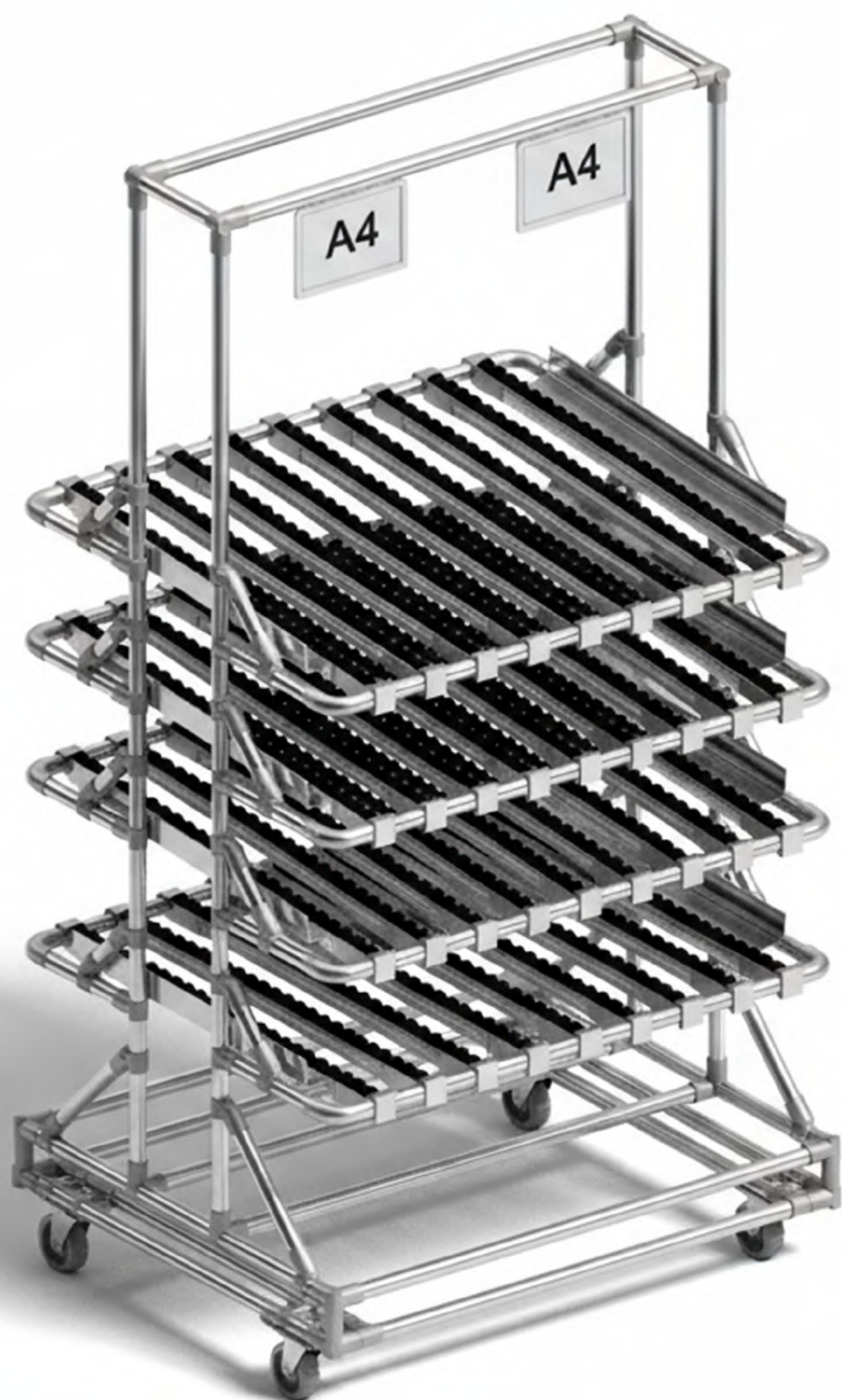

Product Catalog



CONTENTS

PIPES **P**
Series



P03

METAL ACCESSORIES **MA**
Series



P40

METAL JOINTS ASSEMBLING SETS **CVJA**
Series



P09

FASTENERS **F**
Series



P48

METAL JOINTS **CV**
Series



P15

CASTERS & FEETS **CT**
Series



P52

ALUMINUM JOINTS ASSEMBLING SETS **AL**
Series



P19

TOOLS **T**
Series



P60

ROLLER TRACKS **RT**
Series



P23

VISUAL EQUIPMENTS **VE**
Series



P64

PLASTIC ACCESSORIES **PA**
Series



P30

TRAILER EQUIPMENTS **TT**
Series



P69

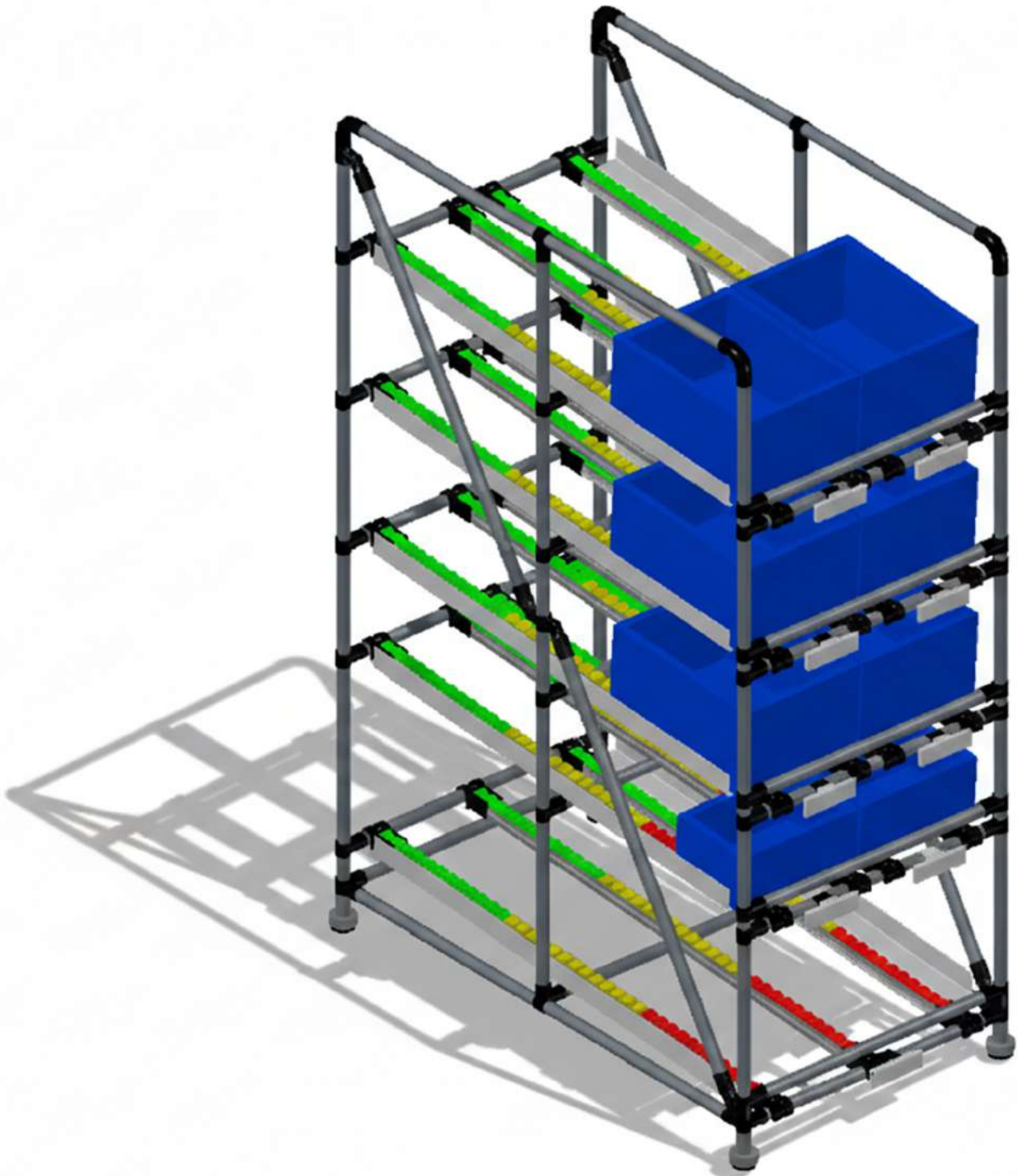



P Series PIPES



PIPES

COATED PIPE	CODE	THICKNESS	LENGTH	COLOUR
	CV-PPC2810	t: 1,0mm	L: 6000mm	 <ul style="list-style-type: none"> GREEN BLUE NAVY BLUE RED ORANGE YELLOW IVORY GREY GILDED GREY BLACK WHITE BROWN
	CV-PPC2815	t: 1,5mm	L: 6000mm	
	CV-PPC2820	t: 2,0mm	L: 6000mm	
POWDER COATED PIPE	CODE	THICKNESS	LENGTH	COLOUR
	CV-PPP2810	t: 1,0mm	L: 6000mm	All Cartela Colours 
	CV-PPP2815	t: 1,5mm	L: 6000mm	
	CV-PPP2820	t: 2,0mm	L: 6000mm	
ESD PIPE	CODE	THICKNESS	LENGTH	COLOUR
	CV-PESD2810	t: 1,0mm	L: 6000mm	 Black
	CV-PESD2815	t: 1,5mm	L: 6000mm	
	CV-PESD2820	t: 2,0mm	L: 6000mm	
STAINLESS STEEL PIPE	CODE	THICKNESS	LENGTH	
	CV-PSSP2812	t: 1,2mm	L: 4000mm	
	CV-PSSP2810	t: 1,0mm	L: 4000mm	
	CV-PSSP2807	t: 0,7mm	L: 4000mm	
GALVANIZED PIPE	CODE	THICKNESS	LENGTH	
	CV-PGLV2820	t: 2,0mm	L: 6000mm	
ALUMINUM ALLOY PIPE	CODE	THICKNESS	LENGTH	
	CV-PALM2820	t: 2,0mm	L: 6000mm	

PIPES

SLIDE PIPE	CODE	THICKNESS	LENGHT
	CV-PPC2810-S	t: 1,0mm	L: 6000mm
CV-PALM2815-B	CODE	THICKNESS	LENGHT
	CV-PALM2815-B	t: 1,5mm	L: 6000mm
CV-PALM2813-C	CODE	THICKNESS	LENGHT
	CV-PALM2813-C	t: 1,3mm	L: 6000mm



Ø28x1mm Maximum Load Limits								
Pipe Length (mm)	750	1000	1250	1500	1750	2000	2250	2500
Load (kg)	115	86	69	57	49	43	38	34

Ø28x1,5mm Maximum Load Limits								
Pipe Length (mm)	750	1000	1250	1500	1750	2000	2250	2500
Load (kg)	165	123	99	82	70	62	54	54

Ø28x2mm Maximum Load Limits								
Pipe Length (mm)	750	1000	1250	1500	1750	2000	2250	2500
Load (kg)	248	185	148	123	106	92	82	74

PIPES

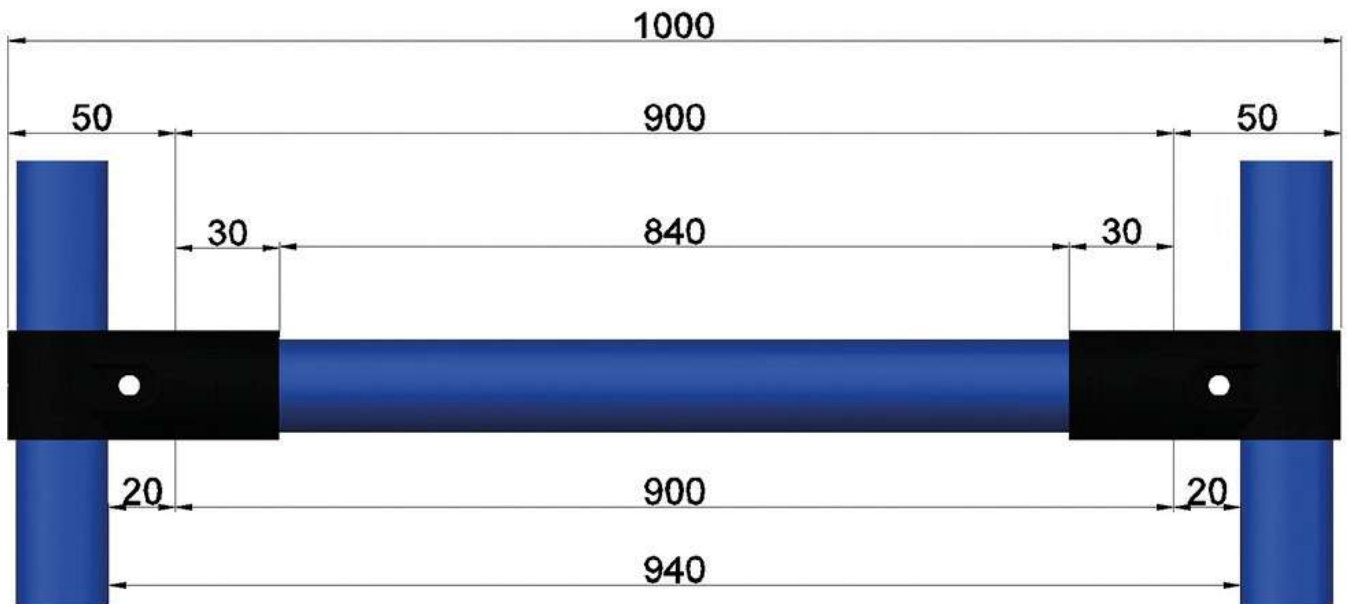

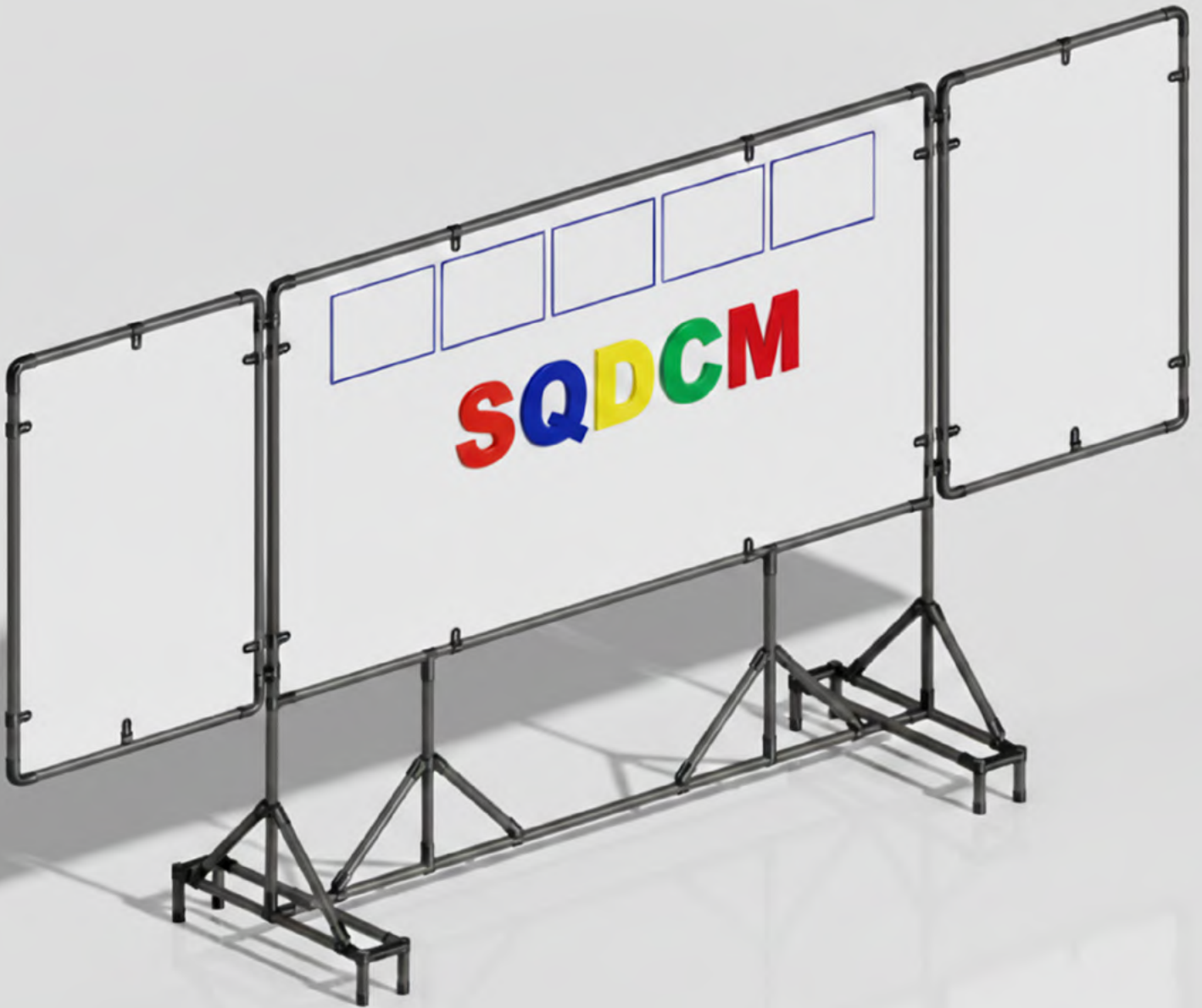

CVJA Series

METAL JOINTS

ASSEMBLING SETS

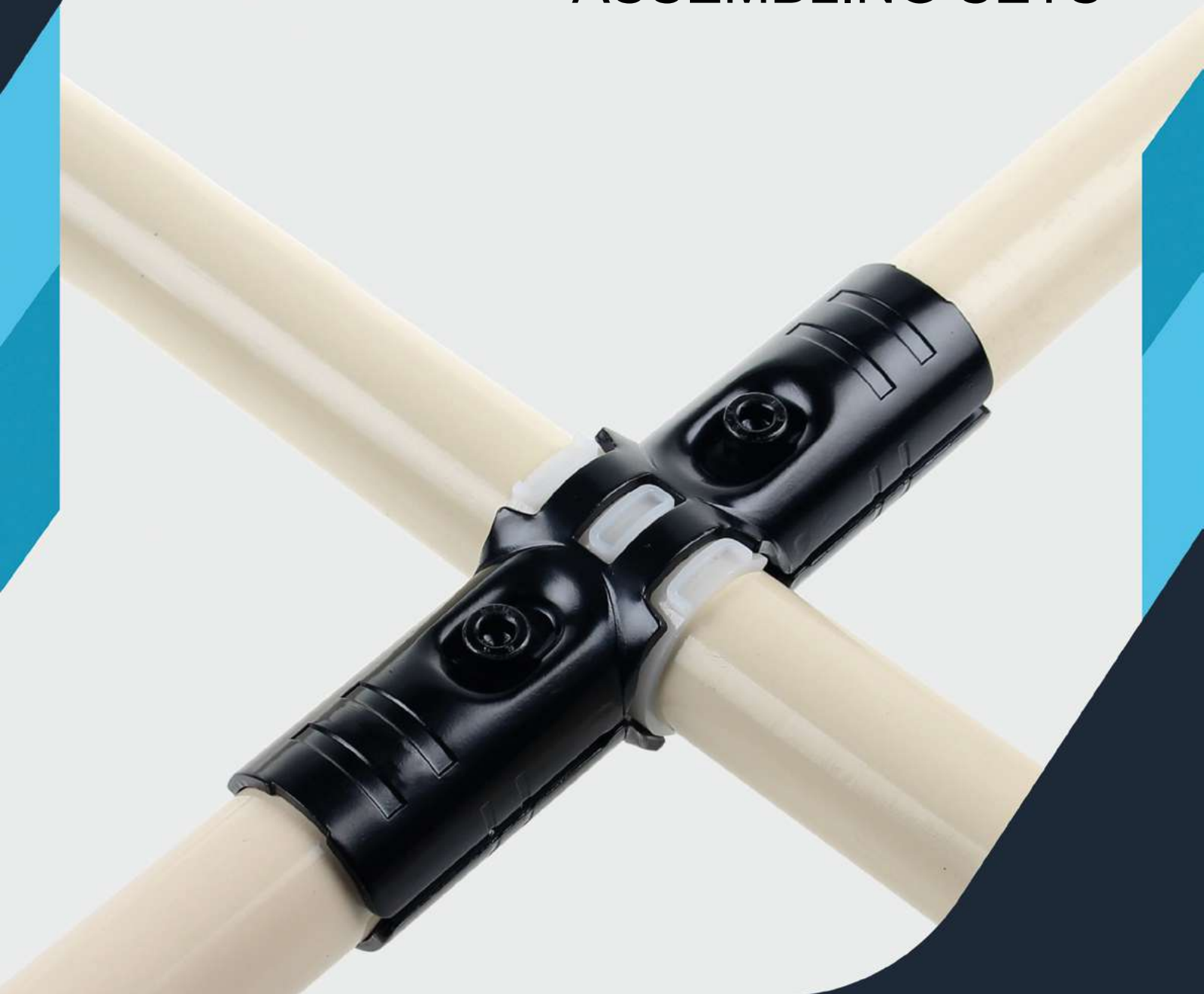

METAL JOINTS ASSEMBLING SETS

CVJA
 Series

CVJA-1



CV-1: 2 pcs CV-M5: 1 Set

CVJA-1A



CV-1A: 2 pcs CV-M5: 1 Set

CVJA-2



CV-2: 1 pcs CV-3: 1 pcs
 CV-M5: 2 Set

CVJA-3

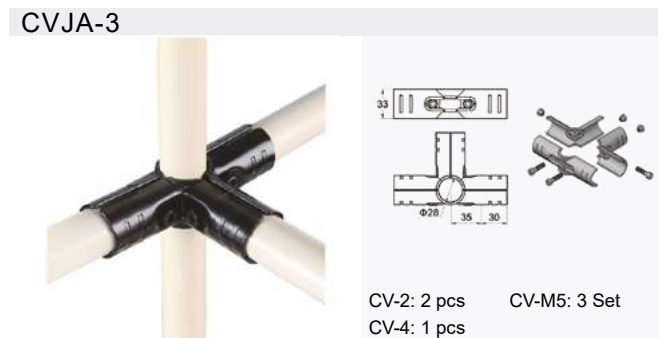

CV-2: 2 pcs CV-4: 1 pcs
 CV-M5: 3 Set

CVJA-4



CV-4: 2 pcs CV-M5: 2 Set

CVJA-5

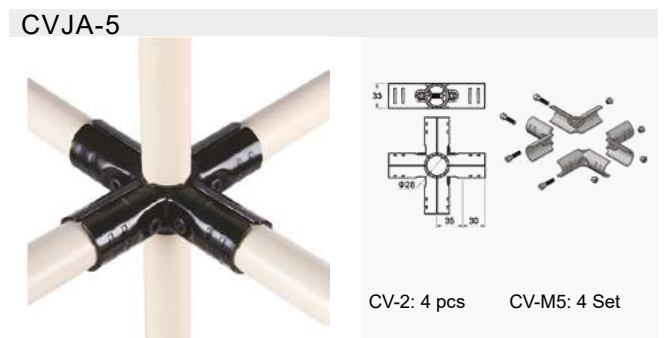

CV-2: 4 pcs CV-M5: 4 Set

CVJA-6



CV-5: 2 pcs CV-6: 2 pcs
 CV-M5: 2 Set

CVJA-6A



CV-6: 2 pcs H-6A: 2 pcs
 CV-M5: 3 Set

CVJA-6B



CV-5: 2 pcs CV-M5: 1 Set

CVJA-6C



H-6A: 2 pcs CV-M5: 2 Set



METAL JOINTS ASSEMBLING SETS

CVJA
 Series

CVJA-13A

H13A: 2 pcs CV-M5: 1 Set

CVJA-H13

H13: 2 pcs CV-M5: 1 Set

CVJA-14

CV-14: 2 pcs CV-M5: 4 Set
 CV-6: 4 pcs

CVJA-14A

CV-14: 2 pcs CV-M5: 2 Set

CVJA-15

CV-15: 1 pcs CV-M5: 1 Set
 CV-16: 1 pcs

CVJA-15A

CV-15: 1 pcs CV-M5: 1 Set
 H-16A: 1 pcs

CVJA-17

CV-17: 1 pc CV-M5: 1 Set
 CV-18: 1 pc

CVJA-19

CV-19: 2 pcs CV-M5: 1 Set
 CV-PLFL: 2 pcs

CVJA-20

CV-20: 2 pcs CV-M5: 1 Set

CVJA-20A

CV-20: 1 pcs CV-M5: 1 Set
 CV-1: 1 pc

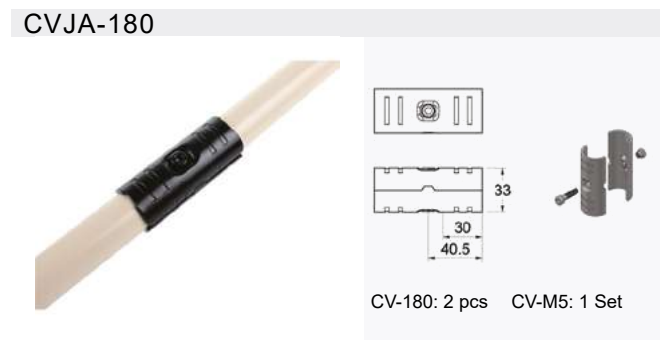

METAL JOINTS (Ø33)

CVJA
Series

CVJA-103

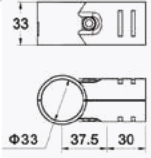
H-103: 2 pcs CV-M5: 1 Set

CVJA-403



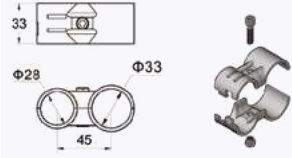

H-403: 2 pcs CV-M5: 2 Set

CVJA-13C

H-13C: 2 pcs CV-M5: 1 Set

CVJA-13D

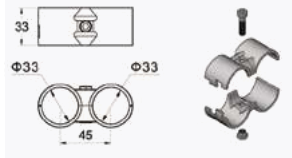
H-13D: 2 pcs CV-M5: 1 Set

CVJA-101

H-101: 2 pc CV-M5: 1 Set

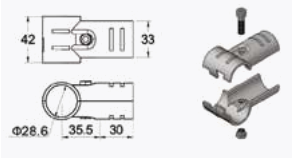
CVJA-102

H-102: 2 pcs CV-M5: 1 Set

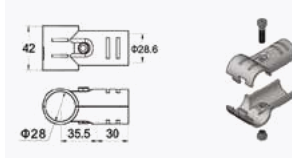
CVJA-201





H-301: 1 pc CV-M5: 2 Set
CV-2: 1 pc

CVJA-301



H-401: 1 pc CV-M5: 3 Set
CV-2: 2 pcs

CVJA-401



H-401: 2 pcs CV-M5: 2 Set

CV Series

METAL JOINTS



METAL JOINTS

CV-1 / E-1



Kg/PC	0,067
PC/CTN	300

CV-1A / E-1C



Kg/PC	0,058
PC/CTN	360

CV-2 / E-2



Kg/PC	0,094
PC/CTN	200

CV-3 / E-3



Kg/PC	0,120
PC/CTN	80

CV-4 / E-4



Kg/PC	0,106
PC/CTN	200

CV-5 / E-7A



Kg/PC	0,045
PC/CTN	300

CV-6 / E-7B



Kg/PC	0,059
PC/CTN	300

CV-7 / E-6



Kg/PC	0,048
PC/CTN	200

CV
Series

CV-7 Aluminum



Kg/PC	0,030
PC/CTN	200

CV-8 / E-22



Kg/PC	0,067
PC/CTN	240

CV-9 / E-21



Kg/PC	0,062
PC/CTN	330

CV-10 / E-16



Kg/PC	0,054
PC/CTN	300

CV-11

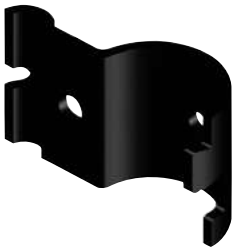

Kg/PC	0,05
PC/CTN	200

CV-12 / E-12



Kg/PC	0,063
PC/CTN	240

CV-13 / E-8



Kg/PC	0,053
PC/CTN	300

CV-14 / E-14



Kg/PC	0,056
PC/CTN	320

CV-15 / E-15B



Kg/PC	0,038
PC/CTN	400

CV-16 / E-15A



Kg/PC	0,046
PC/CTN	400

CV-17 / E-13A



Kg/PC	0,069
PC/CTN	220

CV-18 / E-13B



Kg/PC	0,069
PC/CTN	220

CV-19 / E-18	CV-20	CV-21 / E-9	CV-30
			
Kg/PC 0,062 PC/CTN 150	Kg/PC 0,067 PC/CTN 300	Kg/PC 0,133 PC/CTN 150	Kg/PC 0,062 PC/CTN 330
CV-45	CV-60	CV-90 / E-11	CV-110
			
Kg/PC 0,066 PC/CTN 330	Kg/PC 0,083 PC/CTN 150	Kg/PC 0,102 PC/CTN 150	Kg/PC 0,113 PC/CTN 150
CV-160	CV-180	H-6A / E-7C	H-7A / E-6C
			
Kg/PC 0,114 PC/CTN 160	Kg/PC 0,071 PC/CTN 300	Kg/PC 0,067 PC/CTN 300	Kg/PC 0,067 PC/CTN 300
H-11	H-13	H-13A	H-13C
			
Kg/PC 0,067 PC/CTN 300	Kg/PC 0,053 PC/CTN 300	Kg/PC 0,053 PC/CTN 330	Kg/PC 0,067 PC/CTN 300
H-13D	H-16	H-23 / E-17	H-24 / H-20
			
Kg/PC 0,067 PC/CTN 300	Kg/PC 0,046 PC/CTN 400	Kg/PC 0,067 PC/CTN 300	Kg/PC 0,067 PC/CTN 300

METAL JOINTS (Ø33)

H-101		H-102		H-103		H-301	
							
Kg/PC	0,067	Kg/PC	0,067	Kg/PC	0,067	Kg/PC	0,120
PC/CTN	300	PC/CTN	300	PC/CTN	300	PC/CTN	80
H-401		H-403 / E-4L		CV-PLFL		CV-M5	
							
Kg/PC	0,108	Kg/PC	0,067	Kg/PC	0,008	Kg/PC	0,009
PC/CTN	200	PC/CTN	300	PC/CTN	150	PC/CTN	2000 set

CV
Series

AL Series

ALUMINUM JOINTS ASSEMBLING SETS



ALUMINUM JOINTS ASSEMBLING SETS

AL
Series

AL-A01

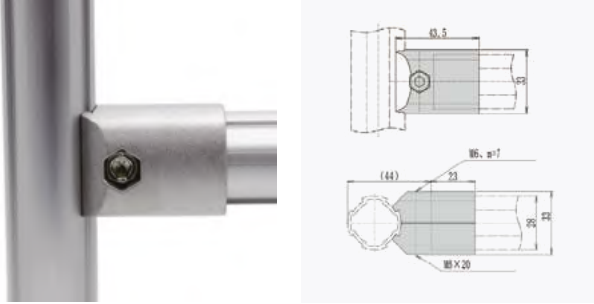

AL-A02

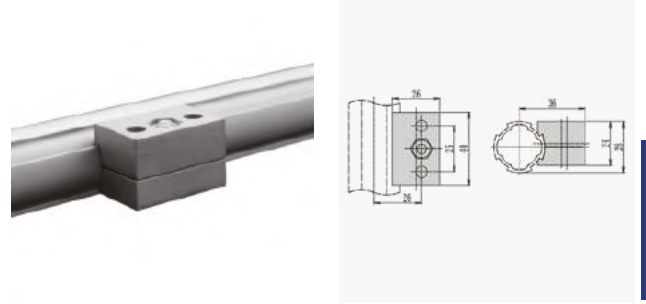

AL-A03

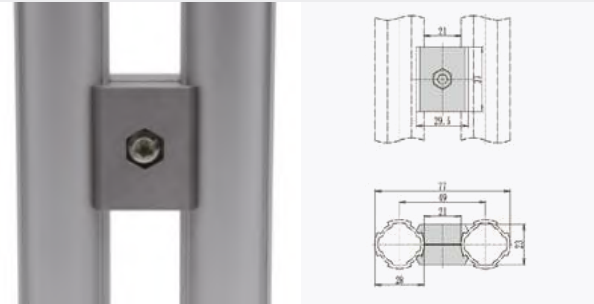

AL-A04

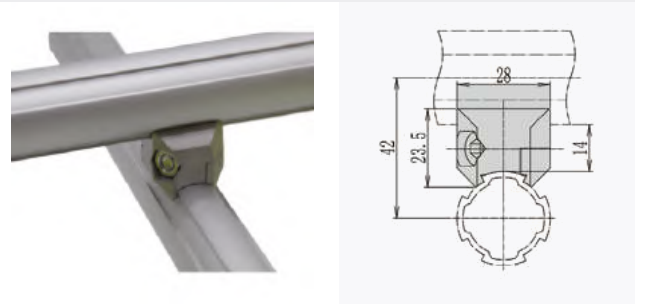

AL-A05

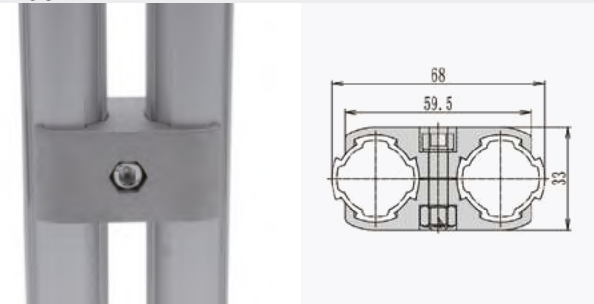

AL-A06

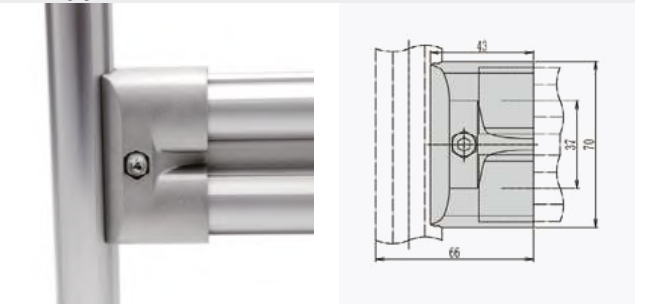

AL-A07

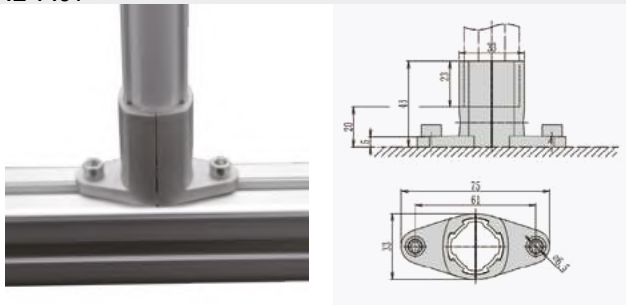

AL-A08

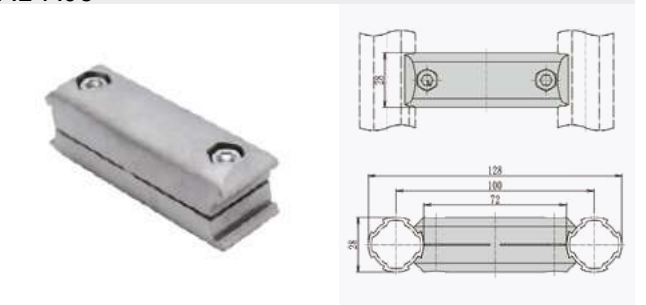

AL-A09

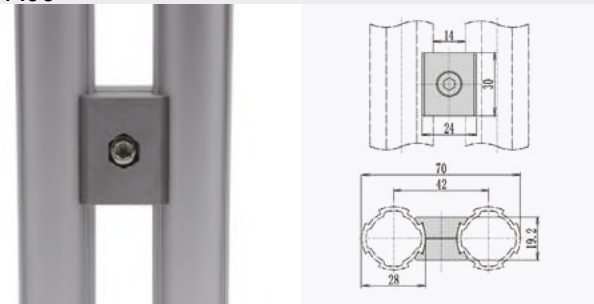

AL-A10

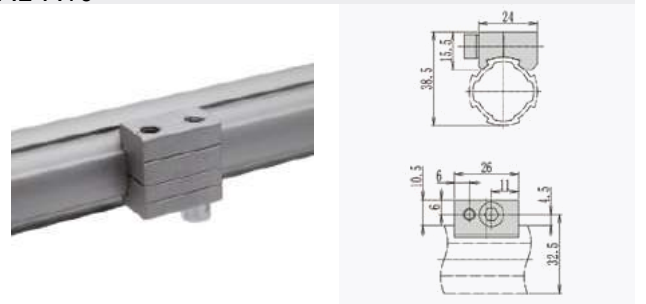

AL-A11

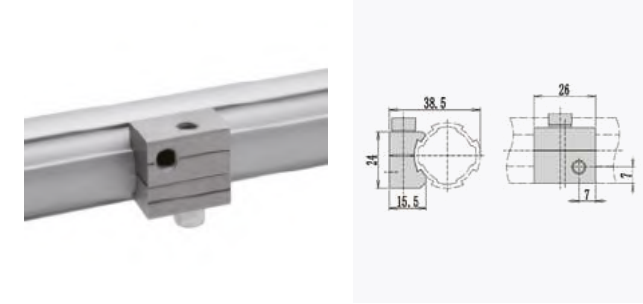

AL-A12

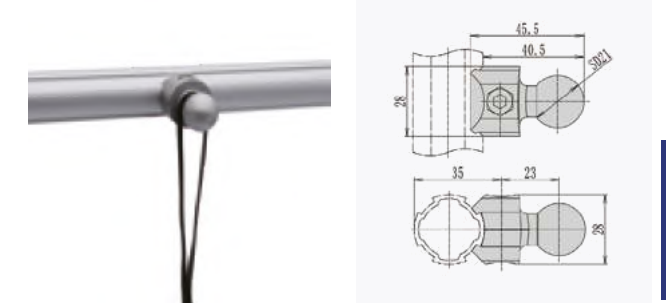

AL-A13

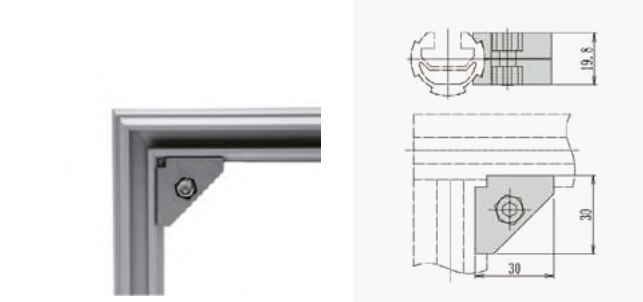

AL-A45

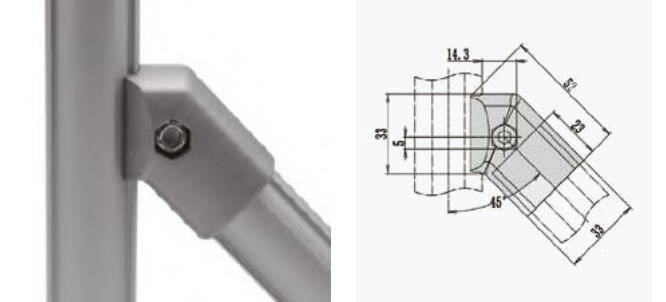

AL-A90

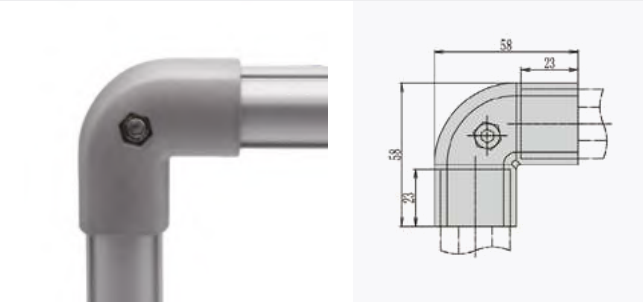

AL-A90D

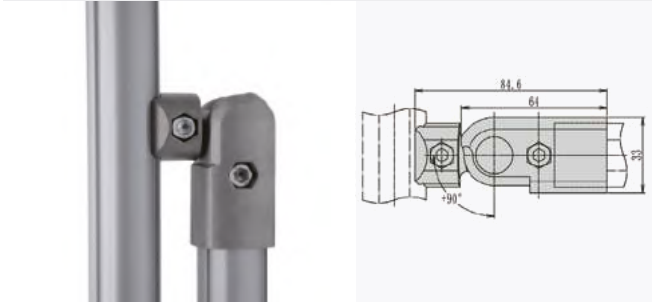

AL-A4545

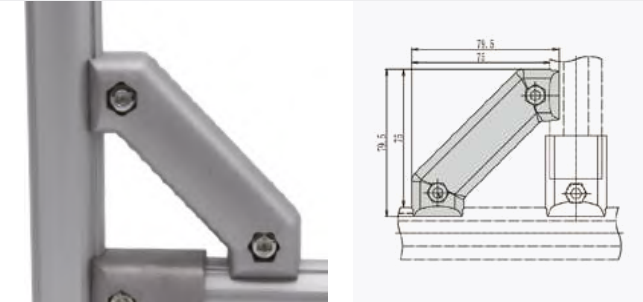

AL-A180

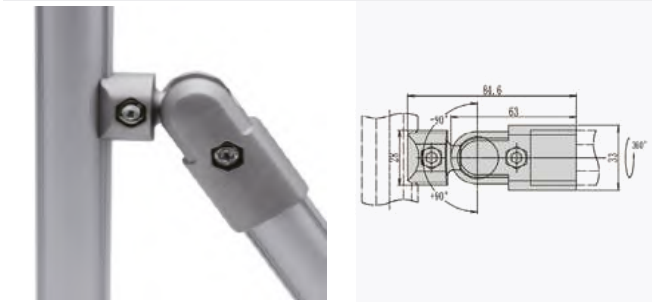

AL-B01

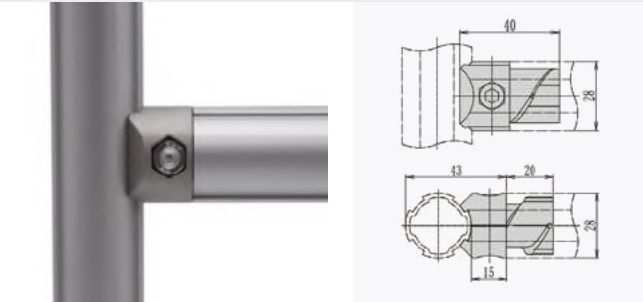

AL-B01D

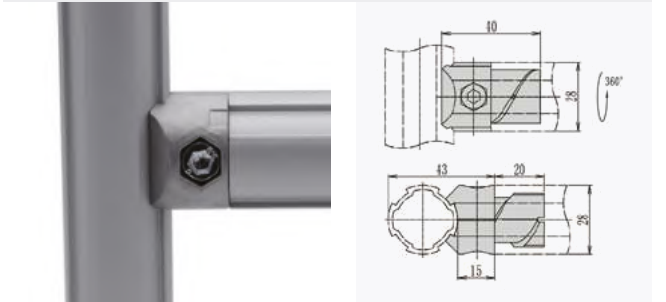

RT Series

ROLLER TRACKS

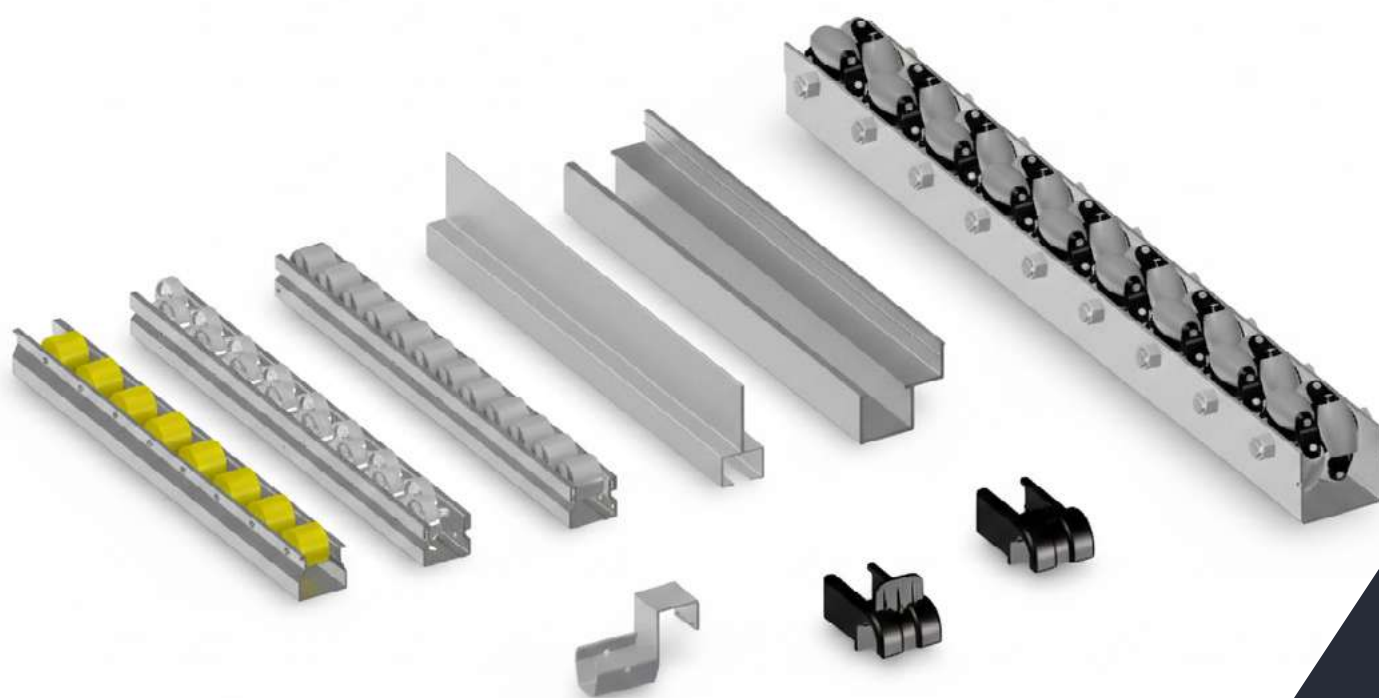

ROLLER TRACKS

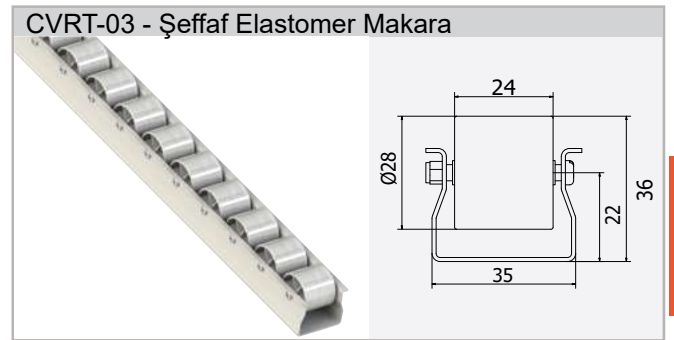
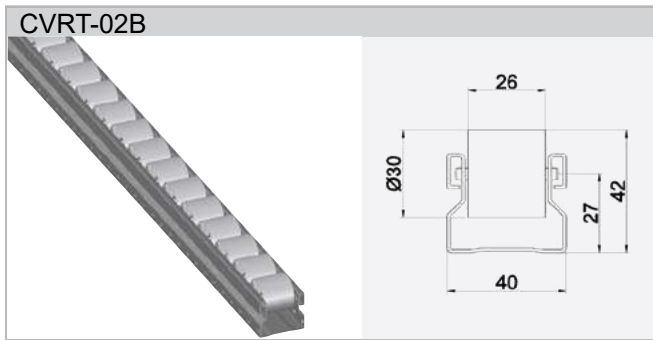
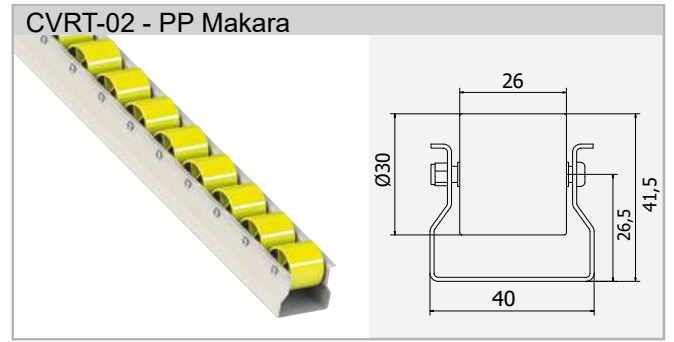
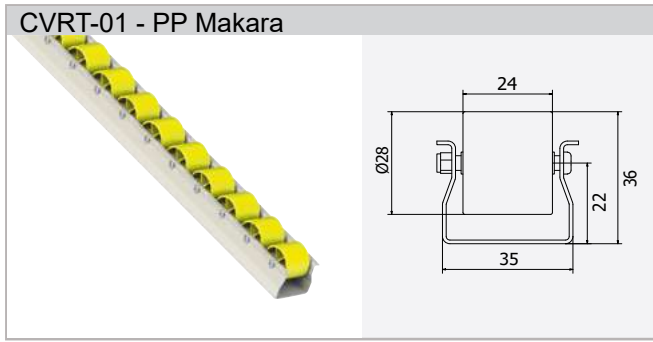

RT
Series

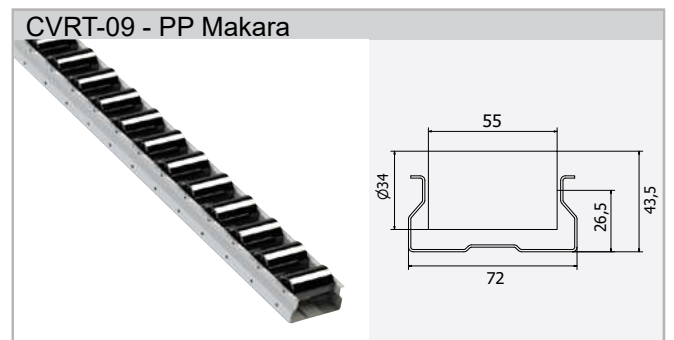
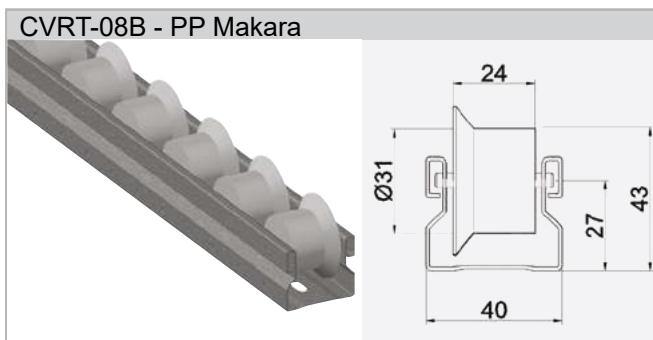
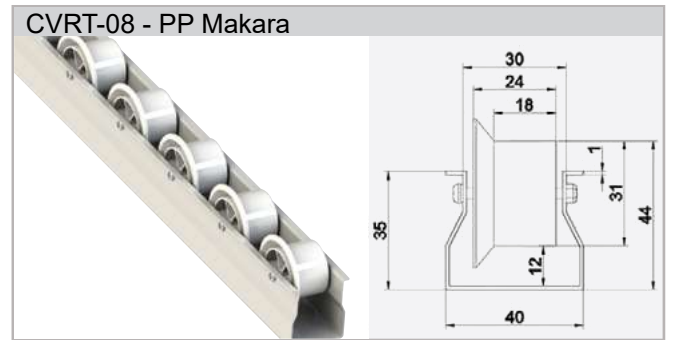
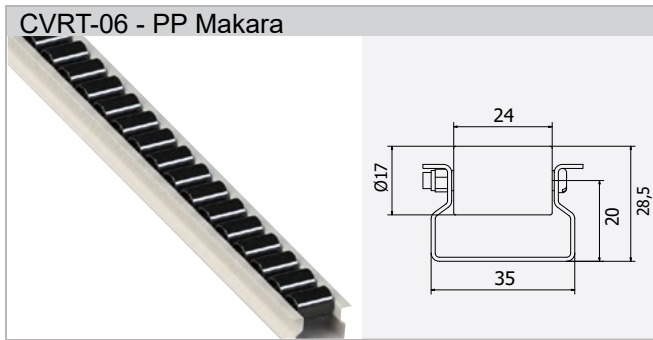
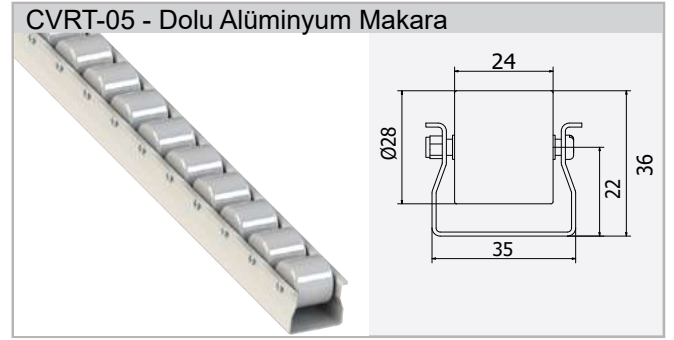
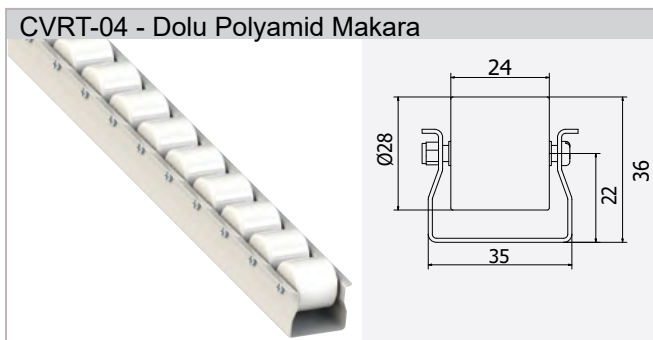

CVRT-10 - Elastomer Makara, Yüzeği Düz

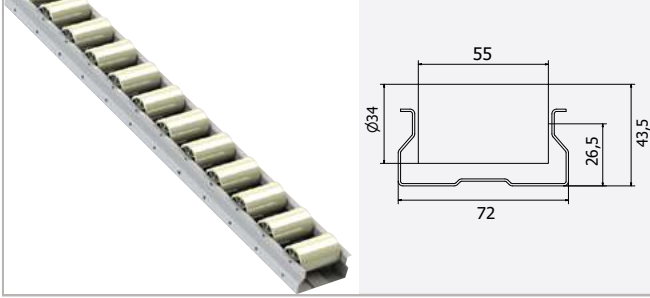

CVRT-11 - Elastomer Makara, Yüzeği Tırtıllı

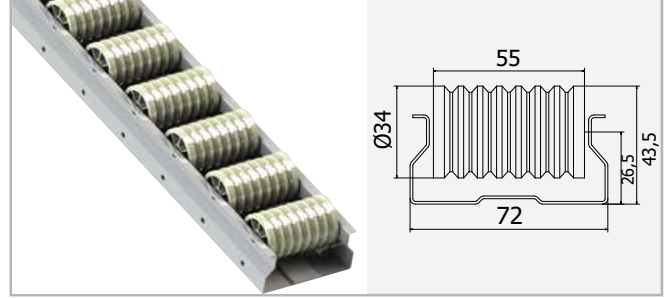

CVRT-12 - PP Makara

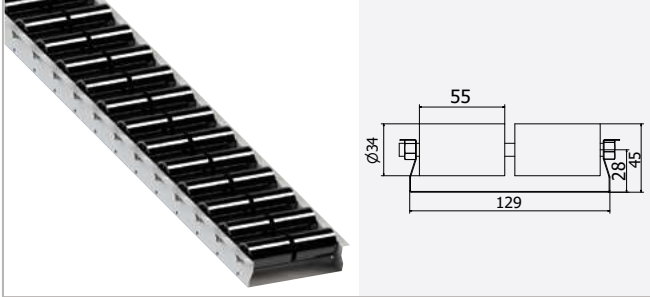

CVRT-13 - Elastomer Makara, Yüzeği Düz

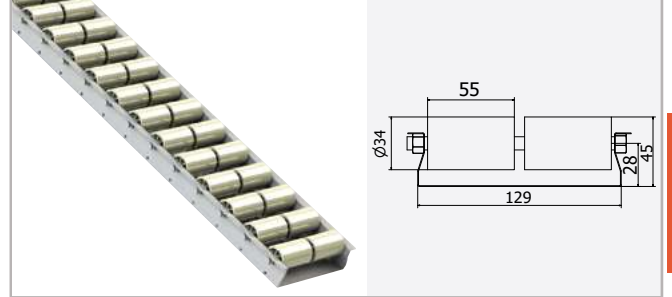

RT
Series

CVRT-14 - Elastomer Makara, Yüzeği Tırtıllı

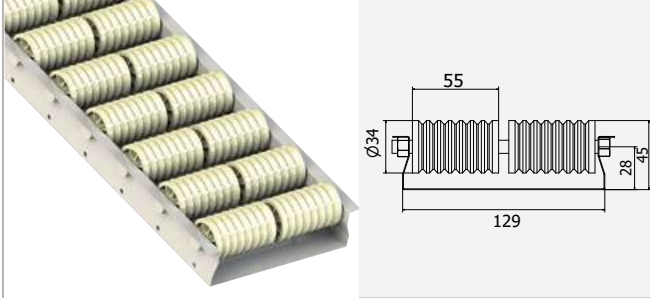

CVRT-15 - PP Makara

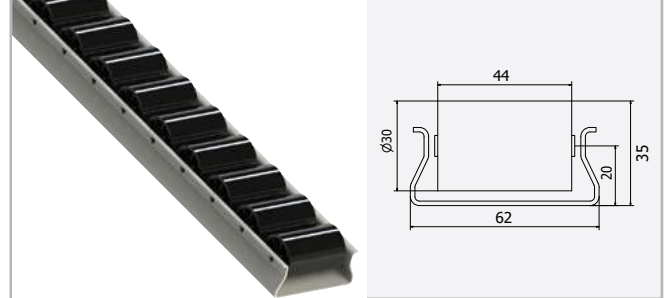

CVRT-16 - PP Makara

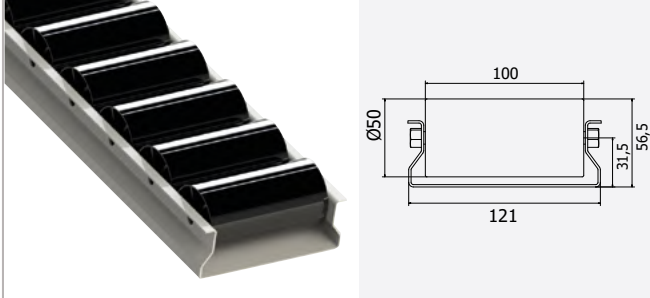

CVRT-17 - PP Makara

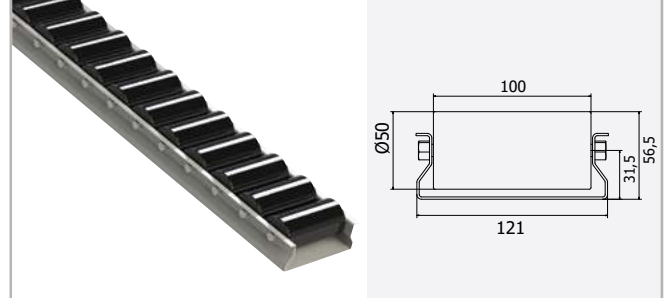

CVRT-18 - PP Makara

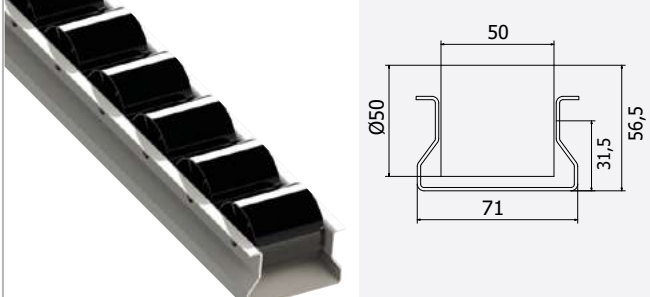

CVRT-19 - PP Makara

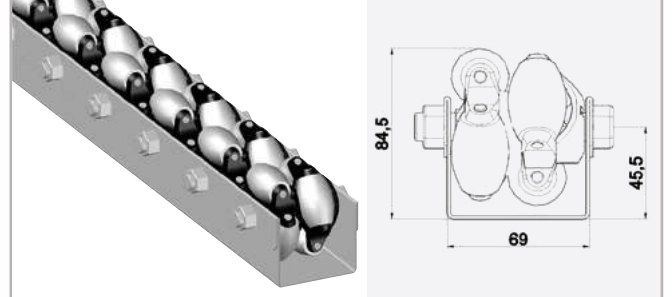

ROLLER TRACKS

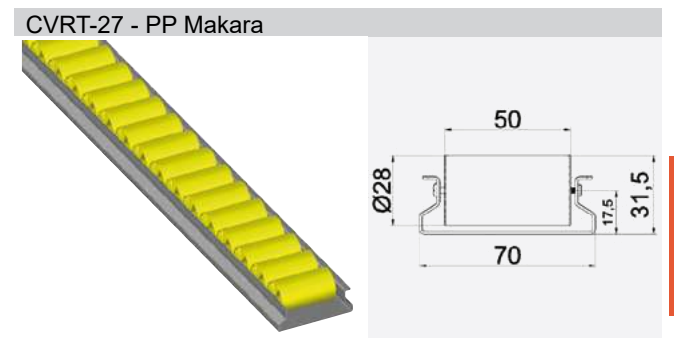
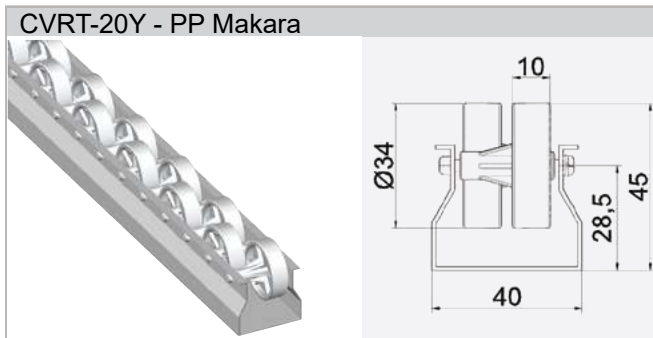
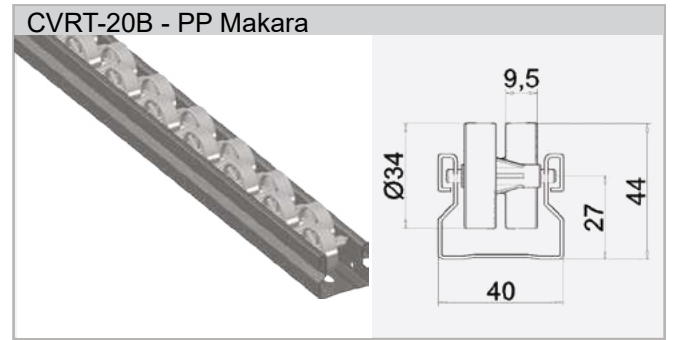
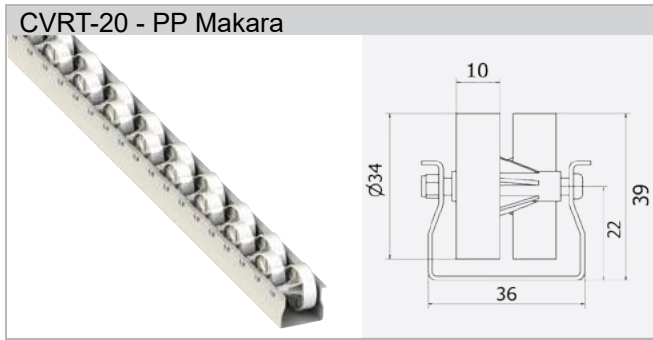

RT
Series

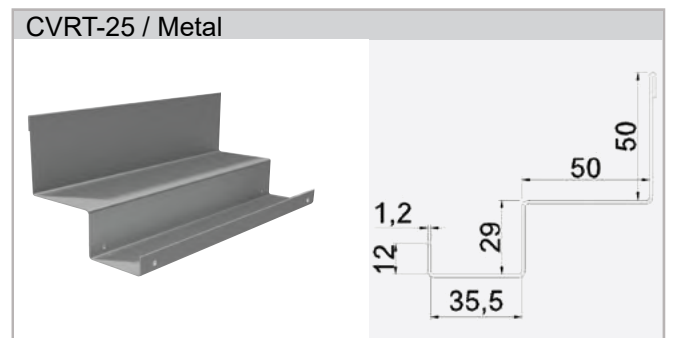
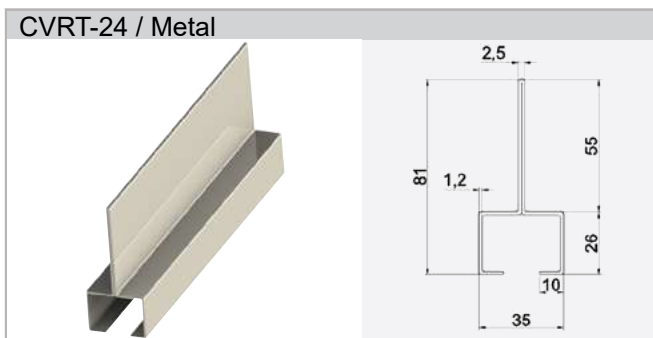
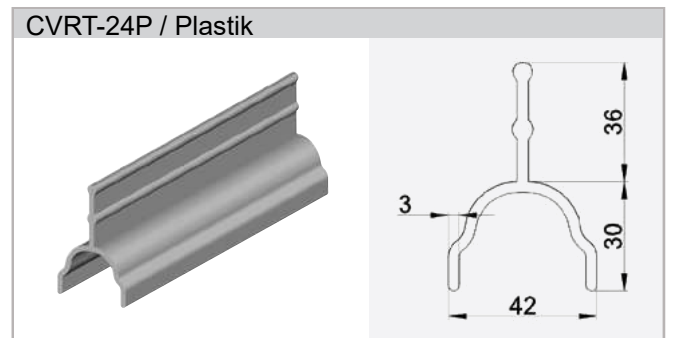
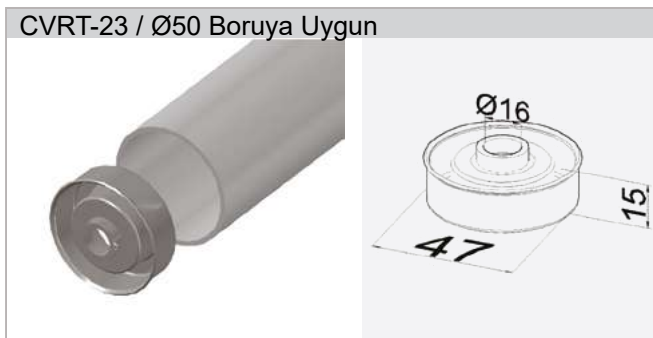
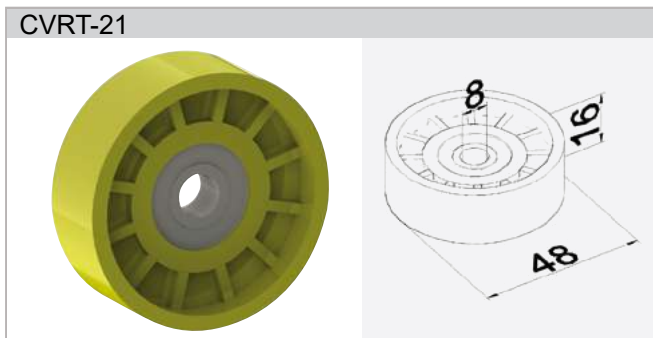

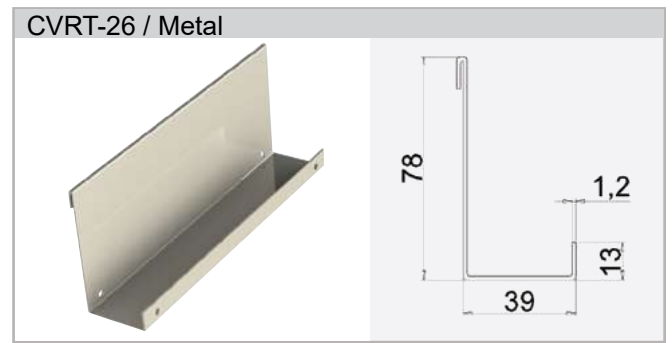
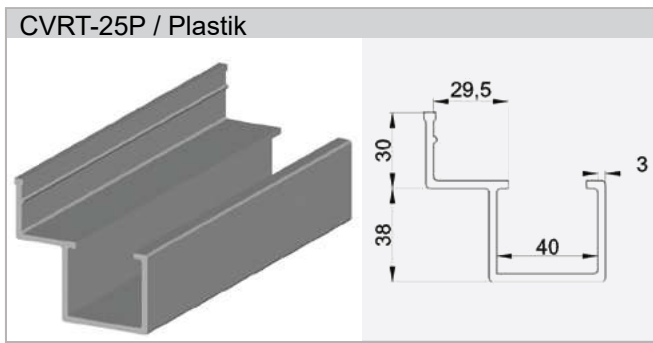

MOUNTING BRACKETS FOR ROLLER TRACKS									
									
Roller Code	Max. Length	ESD Roller	CV-MB01	CV-MB02	CV-MB03	CV-MB04	CV-MB05	CV-MB06	CV-MB07
CV-RT01	6000mm	✓	✓	✓	✓	✓	✓	✓	✓
CV-RT02	6000mm	✓	✓	✓	✓	✓	✓		
CV-RT02B	4000mm	✓	✓	✓	✓	✓	✓		
CV-RT03	6000mm	✓	✓	✓	✓	✓	✓	✓	✓
CV-RT04	6000mm	✓	✓	✓	✓	✓	✓	✓	✓
CV-RT05	3000mm	✓	✓	✓	✓	✓	✓	✓	✓
CV-RT06	3000mm	✓	✓	✓	✓	✓	✓		
CV-RT07	3000mm	✓	✓	✓	✓	✓	✓		
CV-RT08	6000mm	✓	✓	✓	✓	✓	✓		
CV-RT08B	4000mm	✓	✓	✓	✓	✓	✓		
CV-RT09	3000mm	✓	✓	✓	✓	✓	✓		
CV-RT10	3000mm	✓	✓	✓	✓	✓	✓		
CV-RT11	3000mm	✓	✓	✓	✓	✓	✓		
CV-RT12	3000mm	✓	✓	✓	✓	✓	✓		
CV-RT13	3000mm	✓	✓	✓	✓	✓	✓		
CV-RT14	3000mm	✓	✓	✓	✓	✓	✓		
CV-RT15	3000mm	✓	✓	✓	✓	✓	✓		
CV-RT16	3000mm	✓	✓	✓	✓	✓	✓		
CV-RT17	3000mm	✓	✓	✓	✓	✓	✓		
CV-RT18	3000mm	✓	✓	✓	✓	✓	✓		
CV-RT19	3000mm	✓	✓	✓	✓	✓	✓		
CV-RT20	6000mm	✓	✓	✓	✓	✓	✓		
CV-RT20B	4000mm	✓	✓	✓	✓	✓	✓	✓	✓
CV-RT27	3000mm	✓	✓	✓	✓	✓	✓		

RT
Series

ROLLER TRACKS

CV-MB01

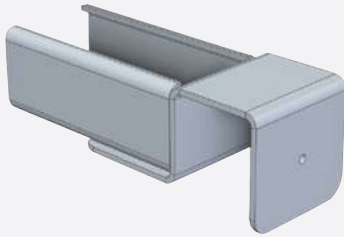

CV-MB02

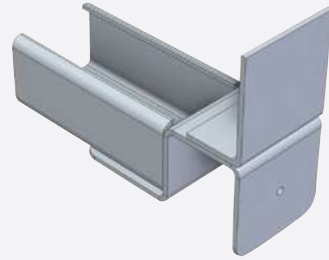

CV-MB03

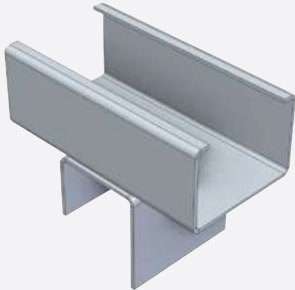

CV-MB04



CV-MB05

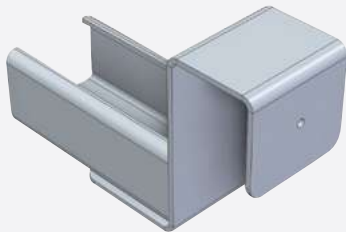

CV-MB06



RT
Series

CV-MB07

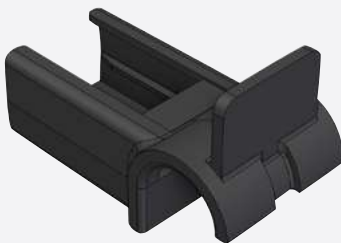

CV-MB08

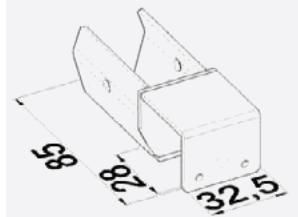

CV-MB09

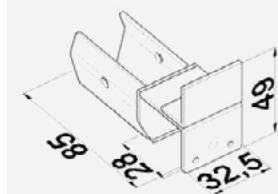

CV-MB10

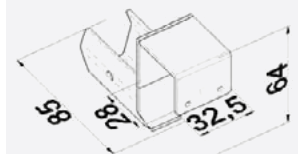

ROLLER TRACKS

CV-MB11

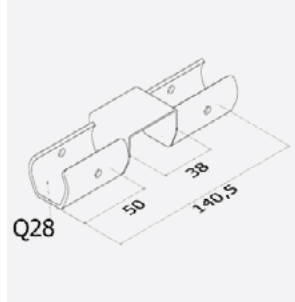

CV-MB12

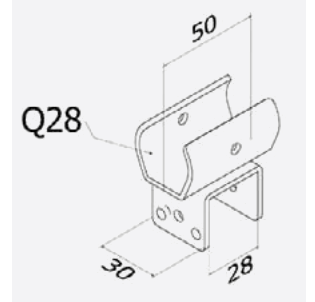

CV-MB13

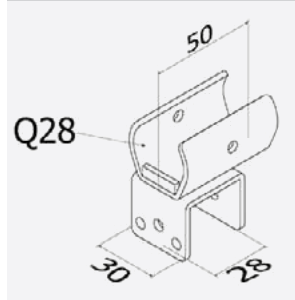

RT
Series

PA Series

PLASTIC ACCESSORIES

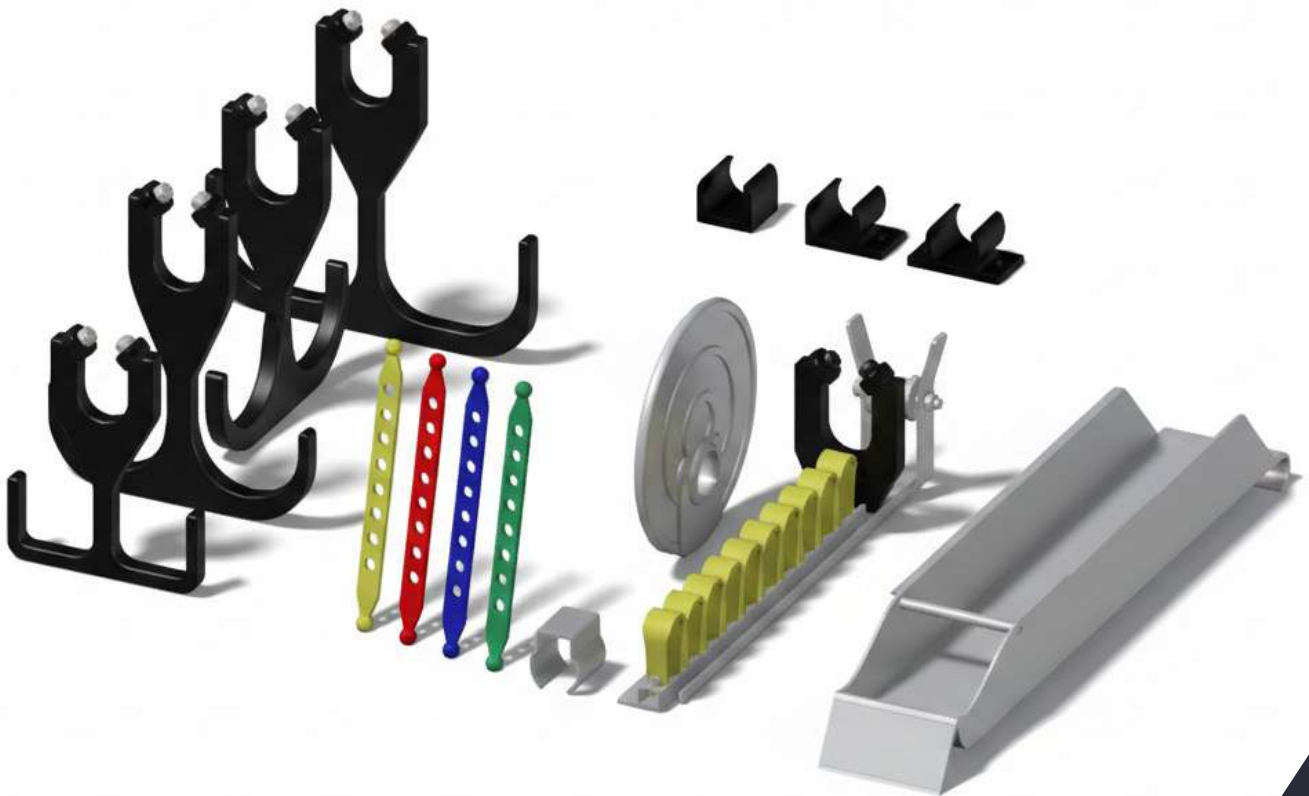

PLASTIC ACCESSORIES

CV-PA01

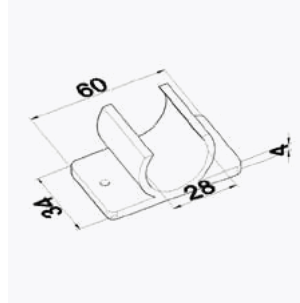

CV-PA02

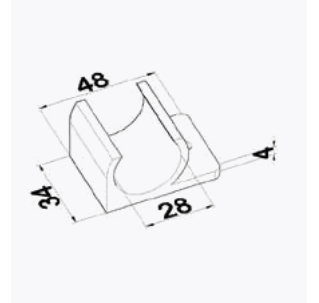
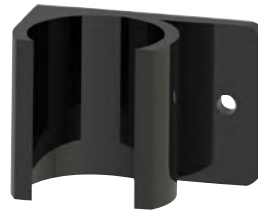

CV-PA03

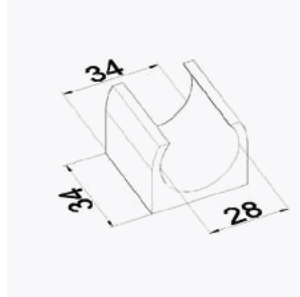

CV-PA04

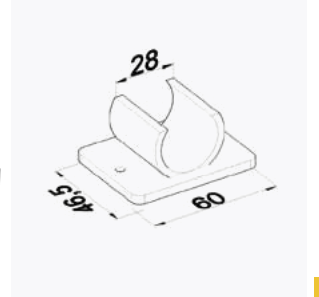

CV-PA05



CV-PA06

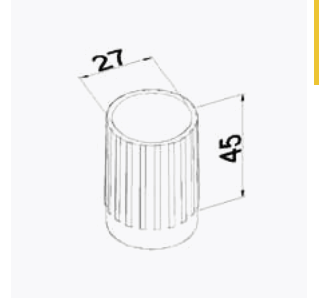

CV-PA06A

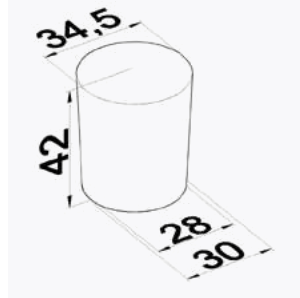

CV-PA07

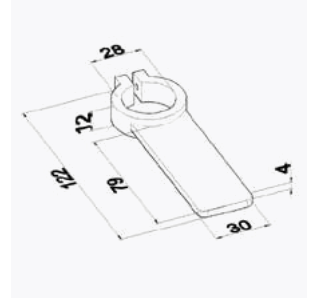

CV-PA08

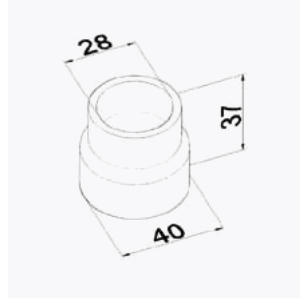

CV-PA09

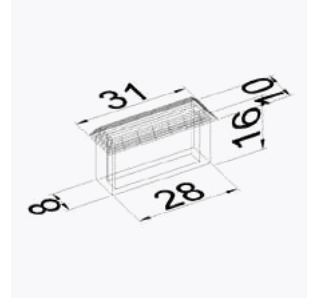

CV-PA10

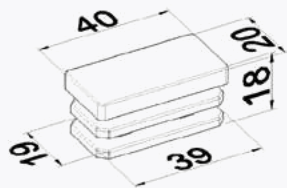

CV-PA11

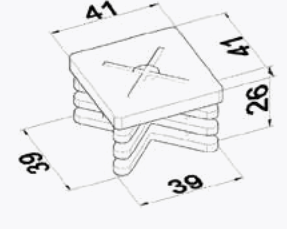

CV-PA12

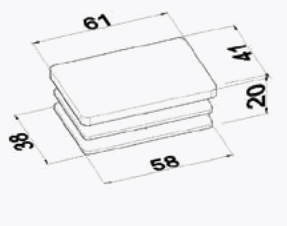

CV-PA13

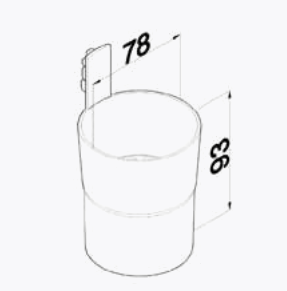

CV-PA14

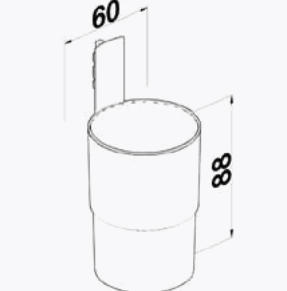

CV-PA15

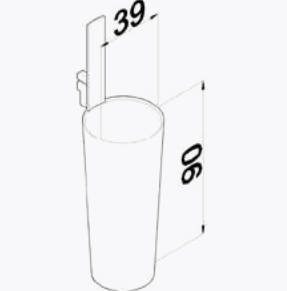

CV-PA19

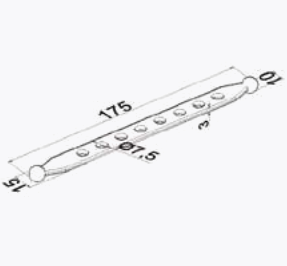

CV-PA20

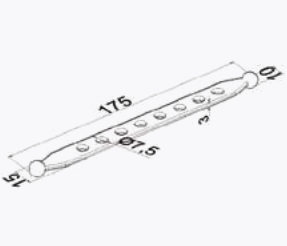

CV-PA21

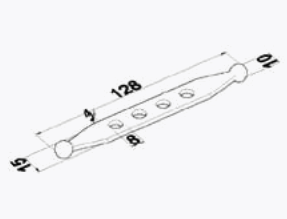
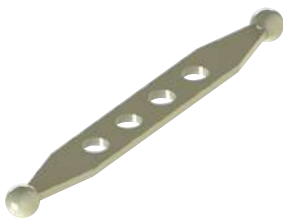

CV-PA22

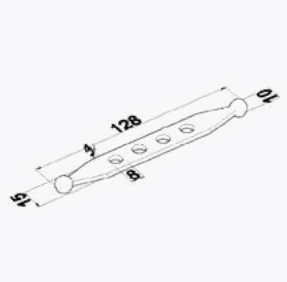

PA
Series

PLASTIC ACCESSORIES

PA
 Series

CV-PA23

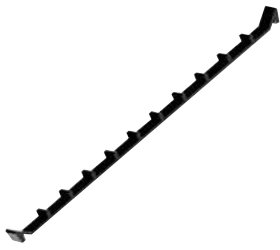

CV-PA24

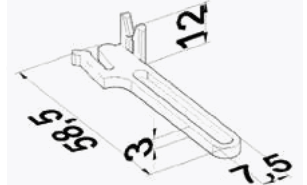

CV-PA25

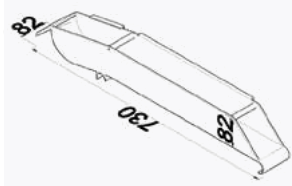

CV-PA26

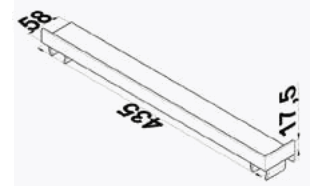
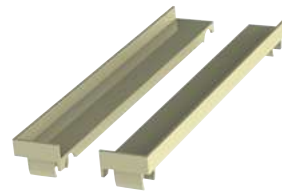

CV-PA27

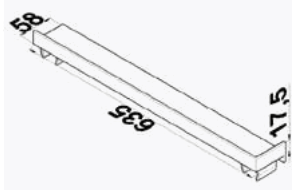
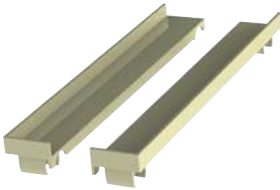

CV-PA67

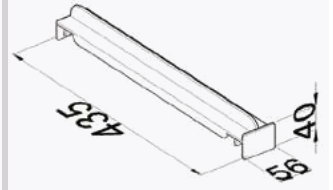

CV-PA68

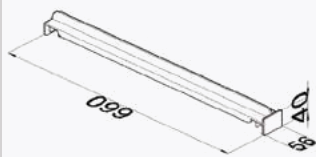

CV-PA28

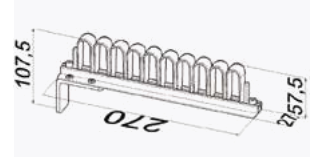
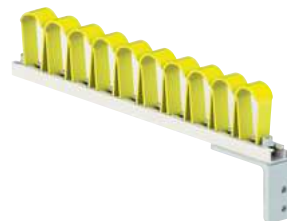

CV-PA29

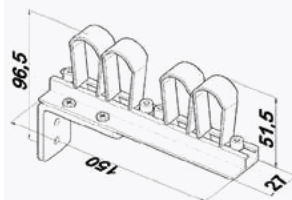

CV-PA30A

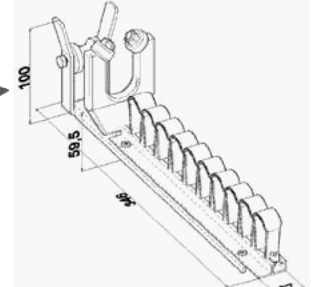
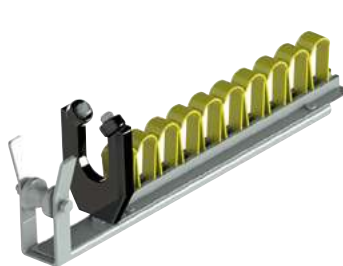

CV-PA30B

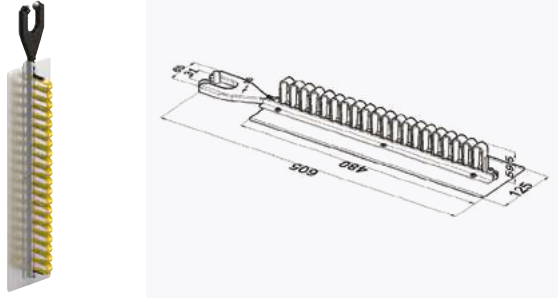

CV-PA31

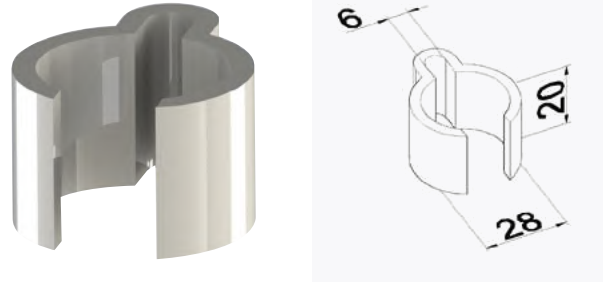

CV-PA32

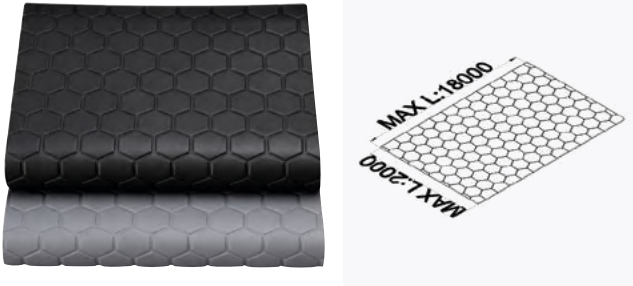

CV-PA33 - 4mm Tek Tarafı Yapışkanlı Sünger

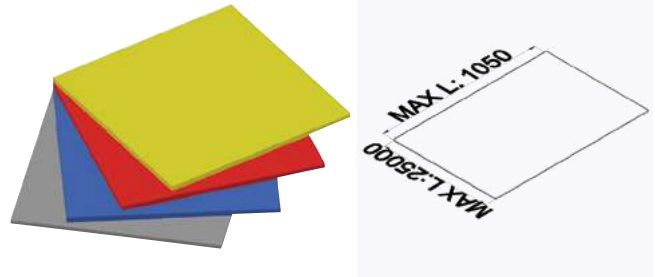

CV-PA34 - 4mm Tek Tarafı Yapışkanlı Sünger Siyah

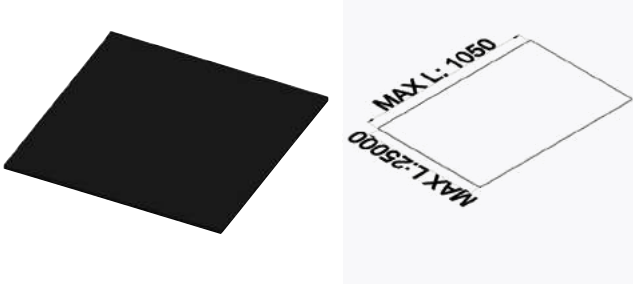

CV-PA35

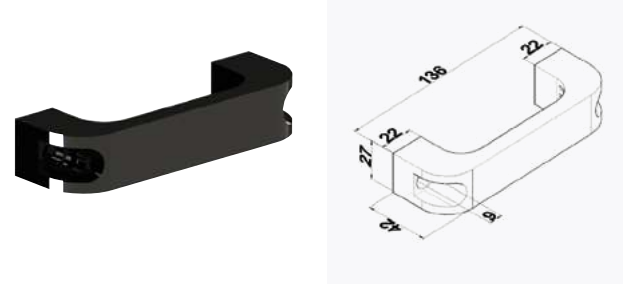

CV-PA36

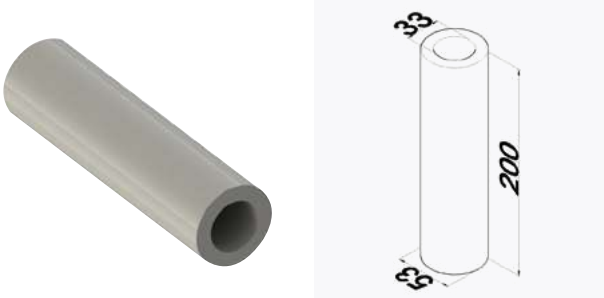

CV-PA37

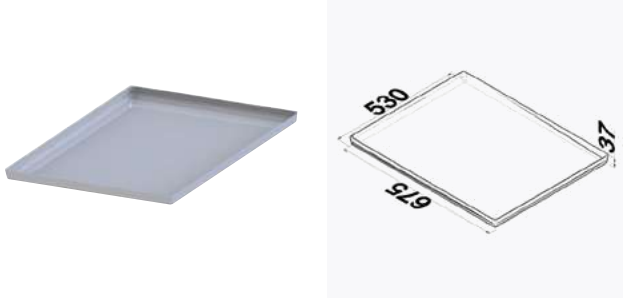

CV-PA38

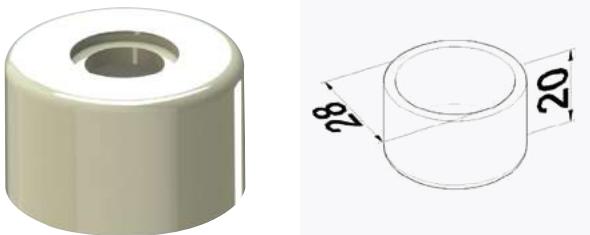

CV-PA39

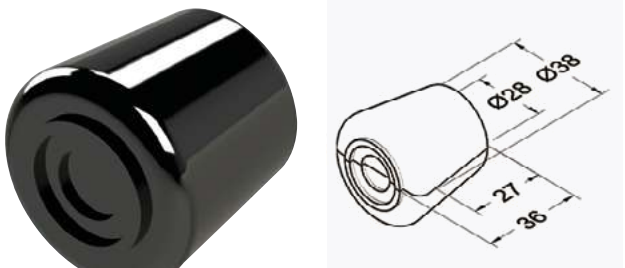

PLASTIC ACCESSORIES

PA
Series

CV-PA40

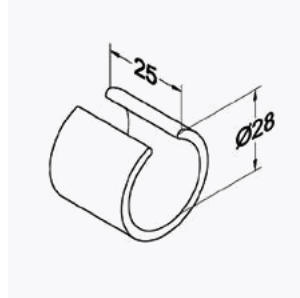
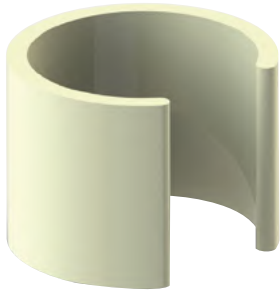

CV-PA41

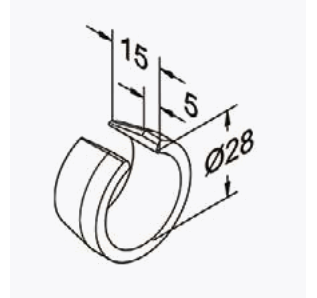
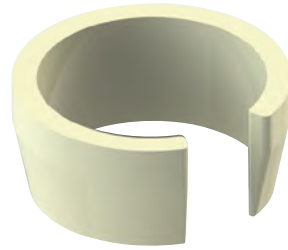

CV-PA42

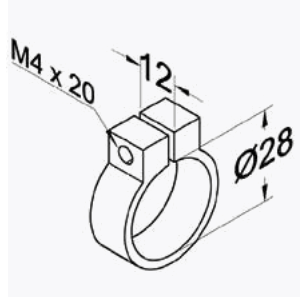
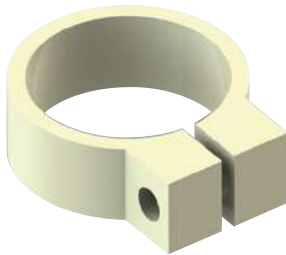

CV-PA43

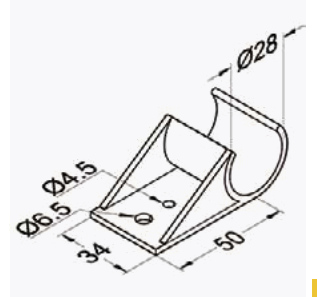
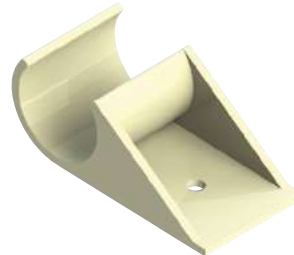

CV-PA44

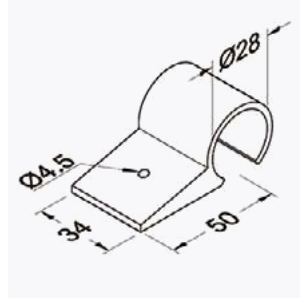

CV-PA45

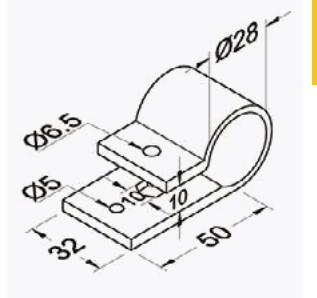
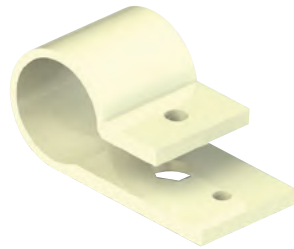

CV-PA46

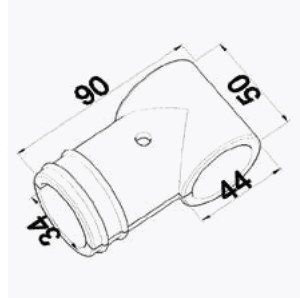

CV-PA47

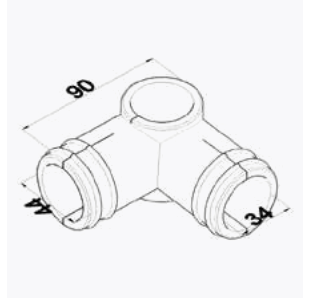

CV-PA48

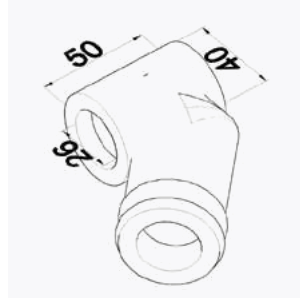

CV-PA49

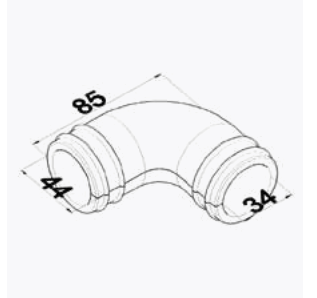

CV-PA50

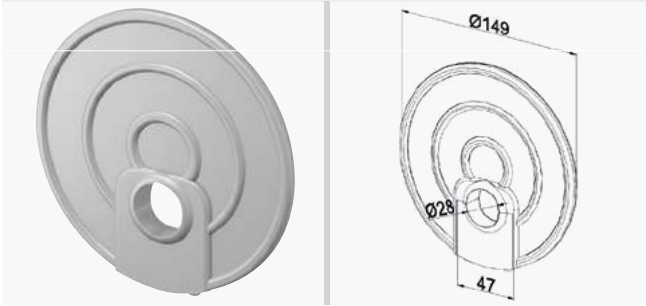

CV-PA51

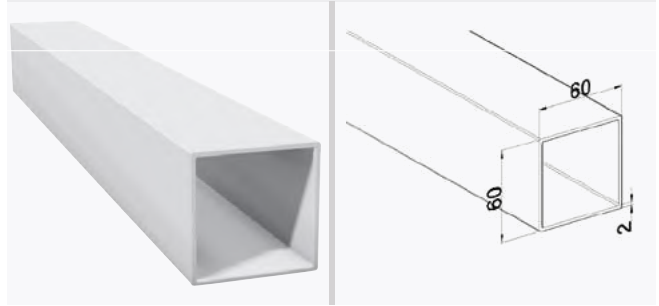

CV-PA52

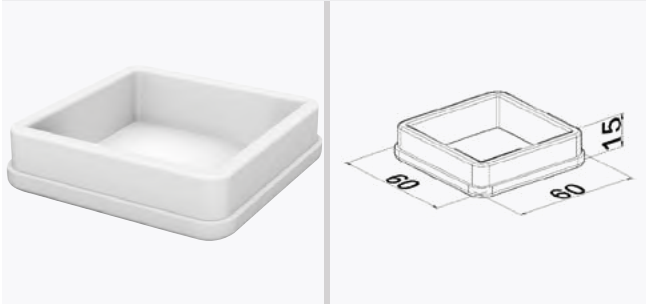

CV-PA53

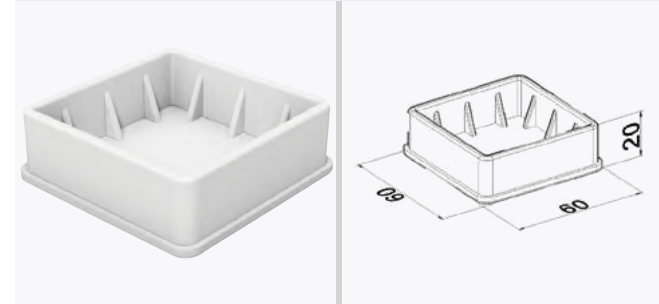

CV-PA54

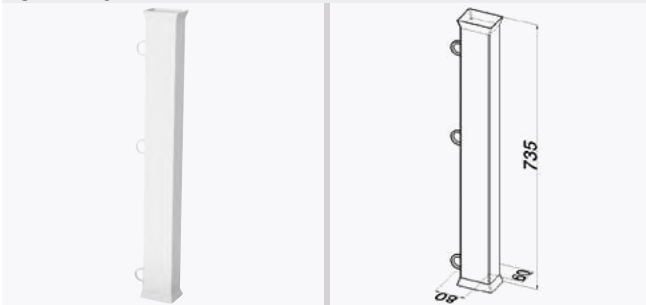

CV-PA55

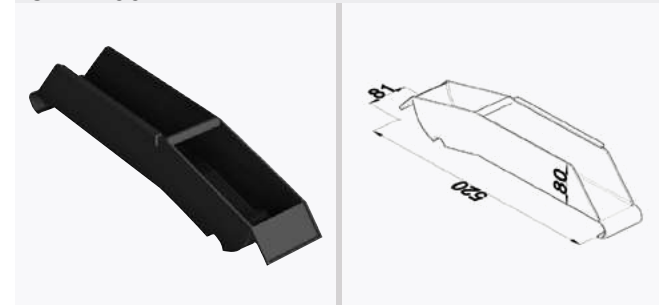

PA
Series

CV-PA56A

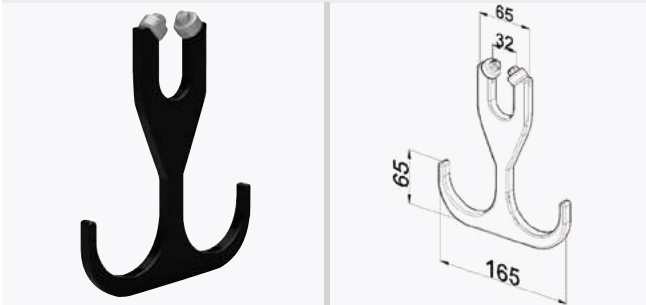

CV-PA56B

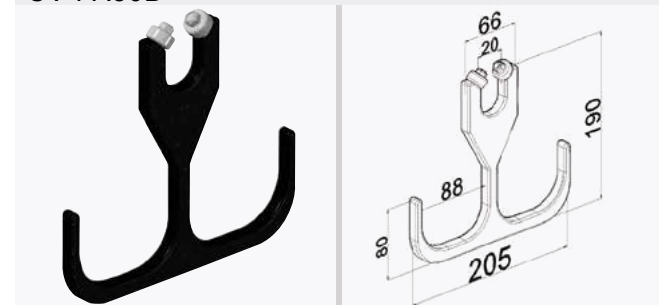

CV-PA56C

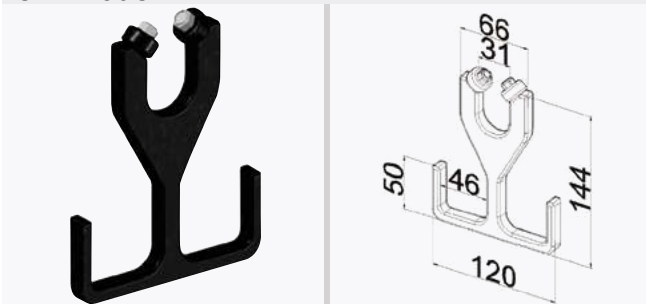

CV-PA57

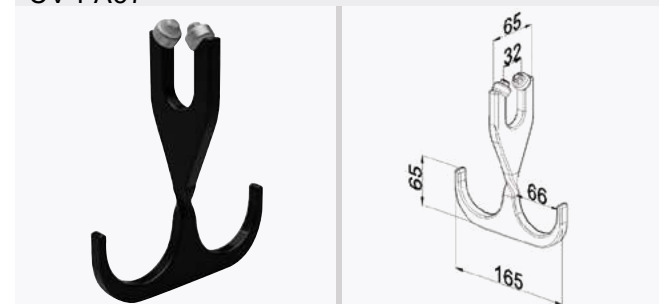

PLASTIC ACCESSORIES

CV-PA59 (CV-MA05B için)

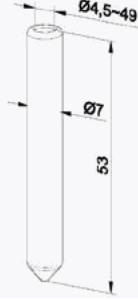

CV-PA58

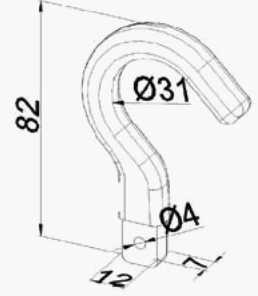

CV-PA60

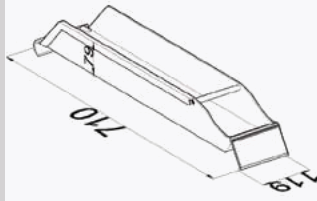
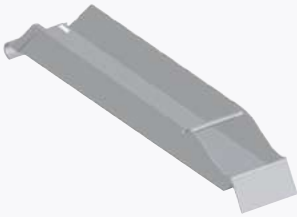

CV-PA61

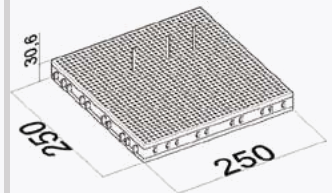
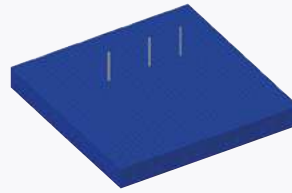

CV-PA63A

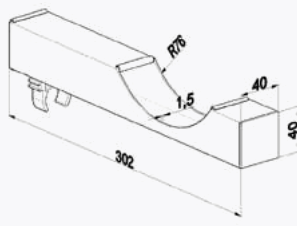

CV-PA63B

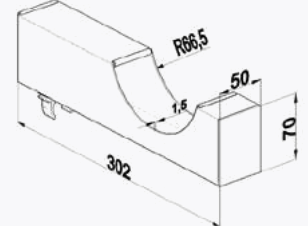

CV-PA64 (CV-MA11 için)

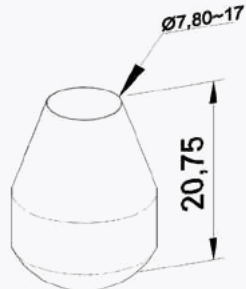

CV-PA65 (CV-PA61 için)

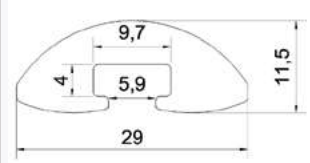

CV-PA66 KONDÜİT AÇICI

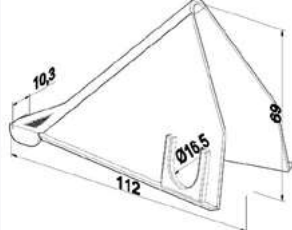

CV-PA69

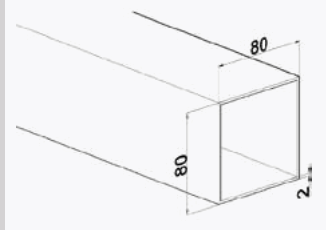
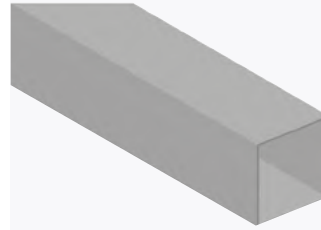

PLASTIC ACCESSORIES

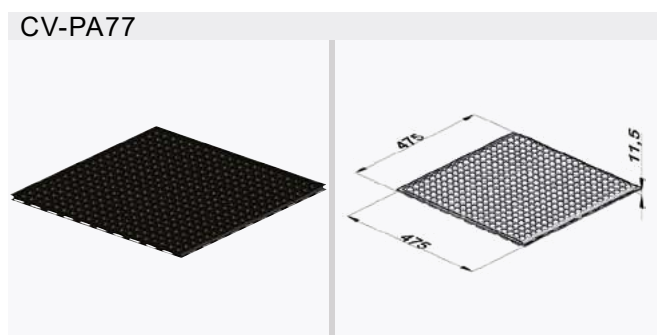
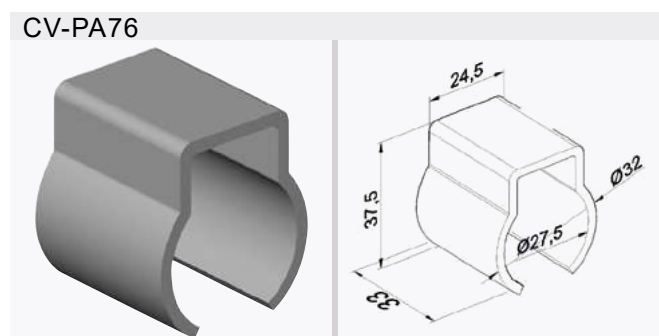
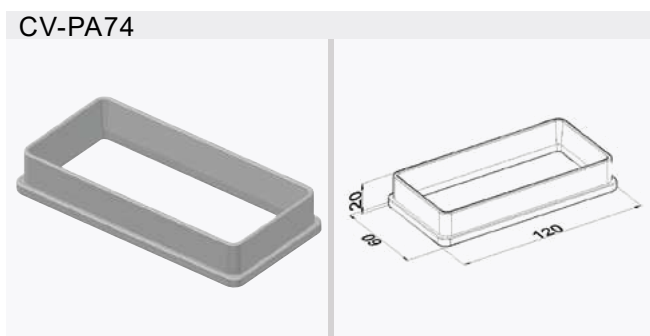
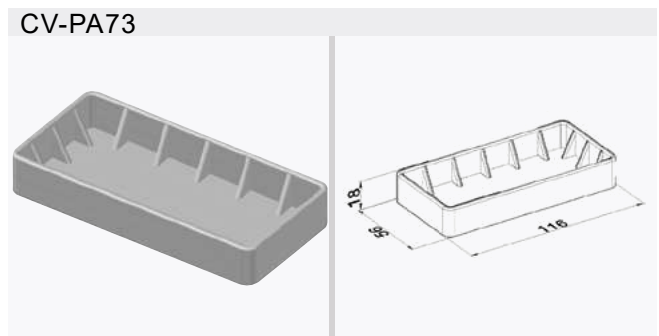
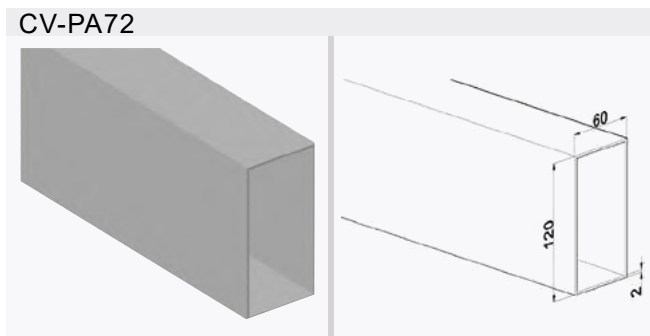
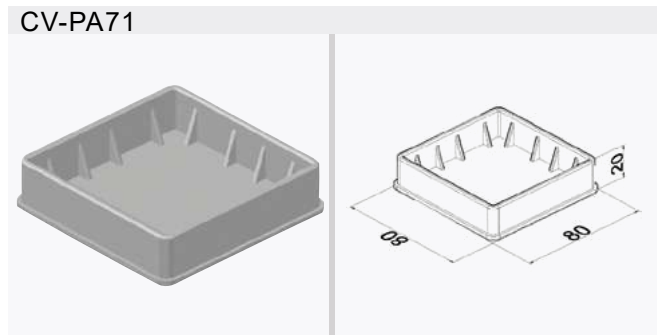
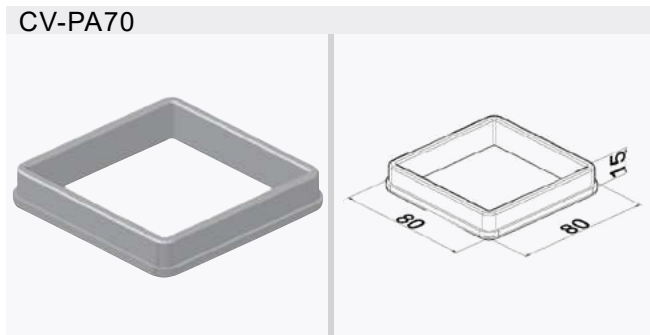

PA
Series

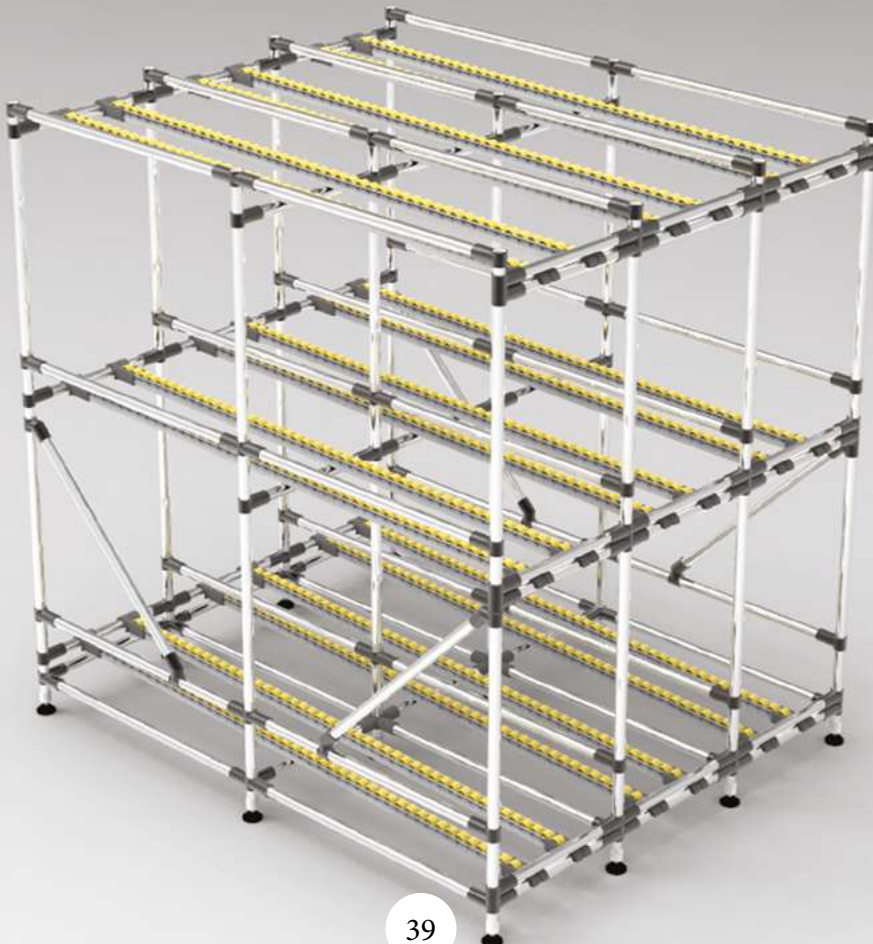
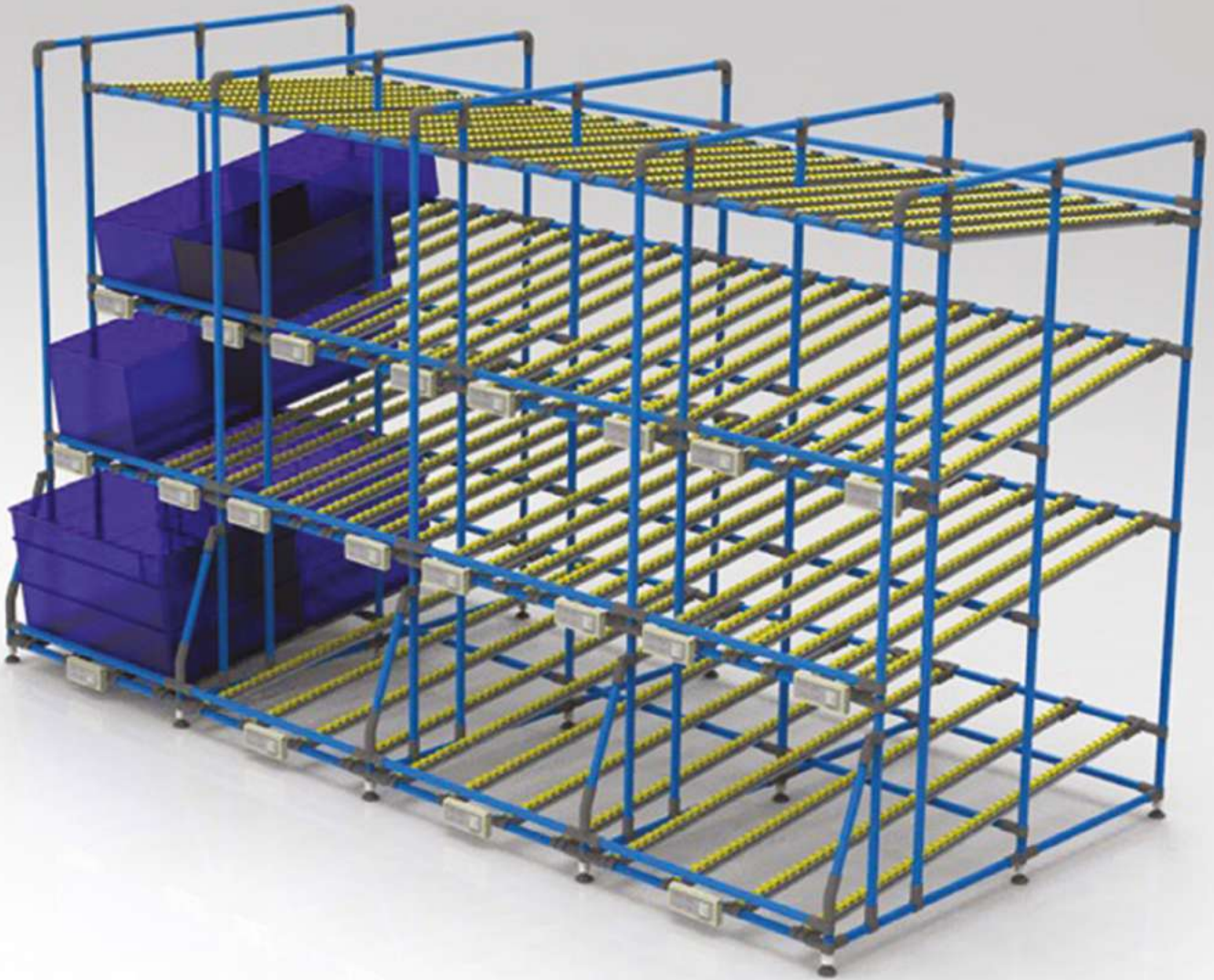

MA Series METAL ACCESSORIES

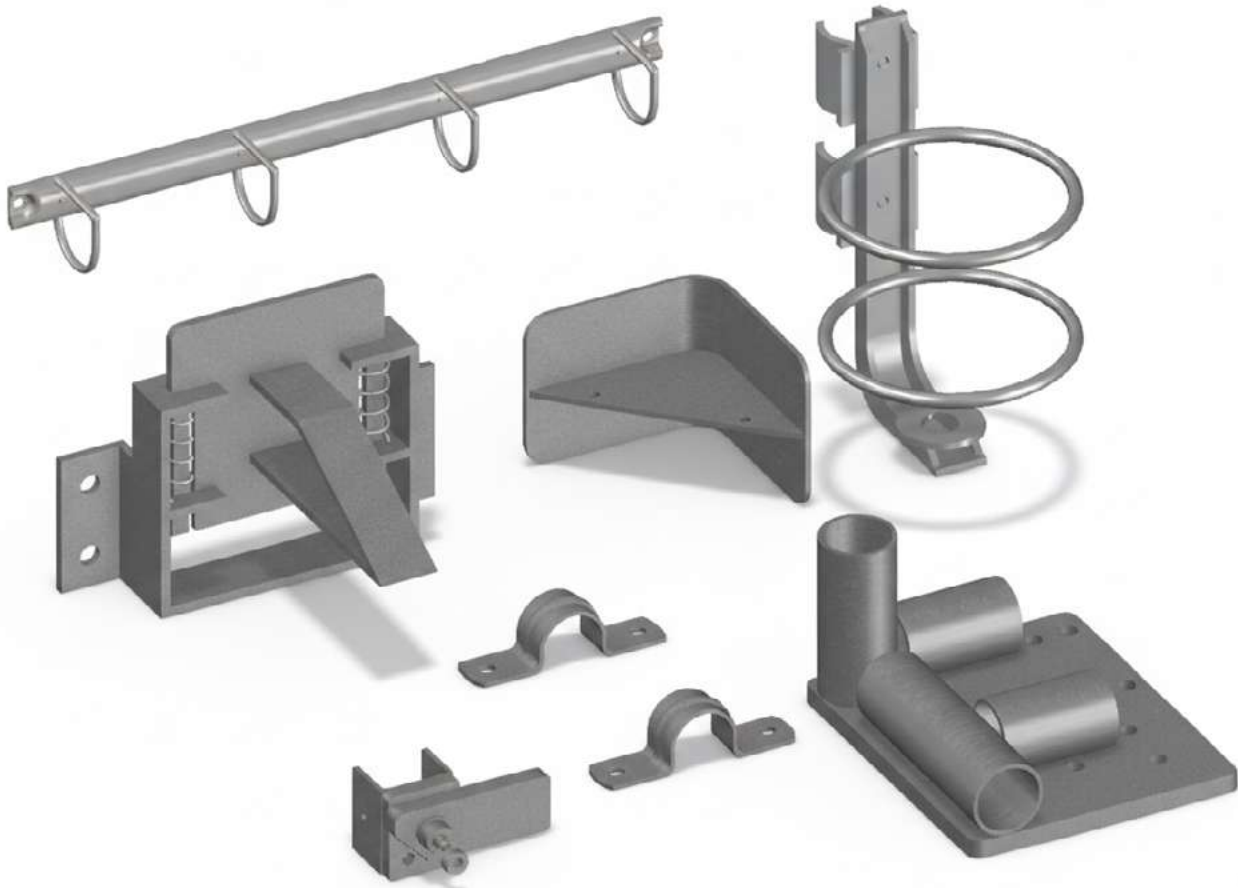

METAL ACCESSORIES

CV-MA01

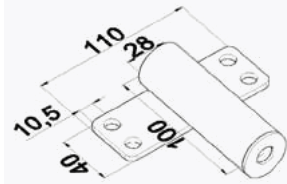

CV-MA02

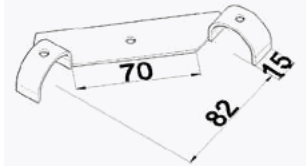

CV-MA03L

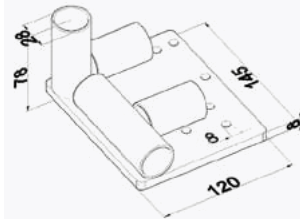

CV-MA03R

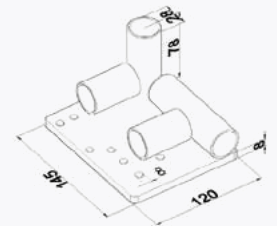

CV-MA04

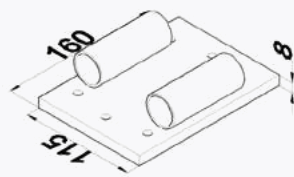

CV-MA04L

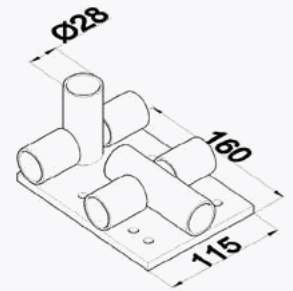

CV-MA04R

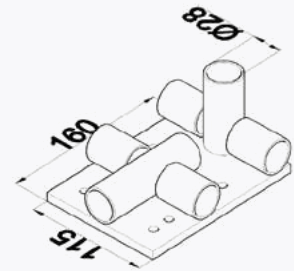

CV-MA05

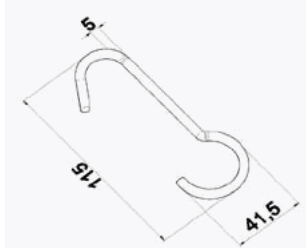

CV-MA05B

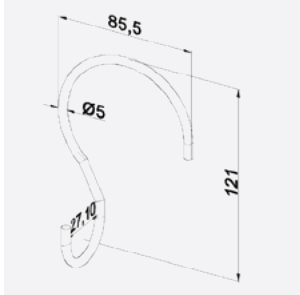

CV-MA06

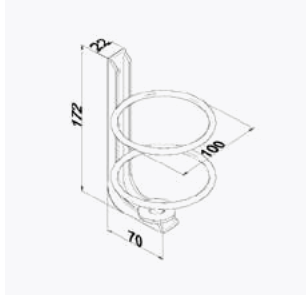

MA
Series

CV-MA07

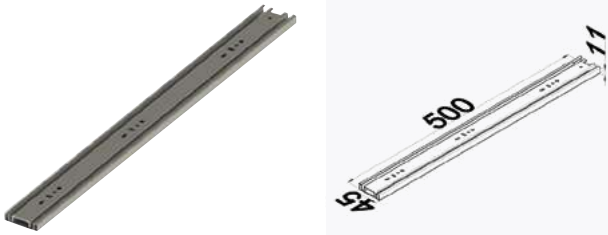

CV-MA10

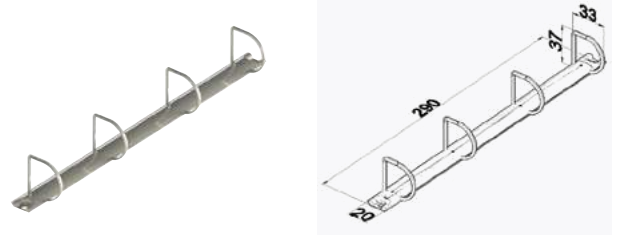

CV-MA11

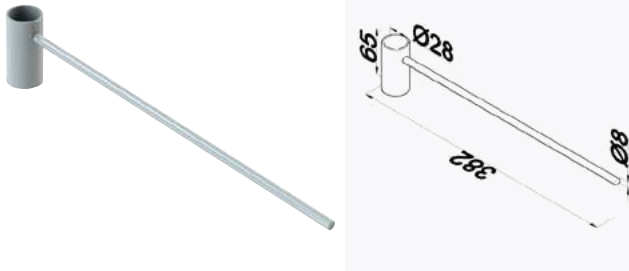

CV-MA12

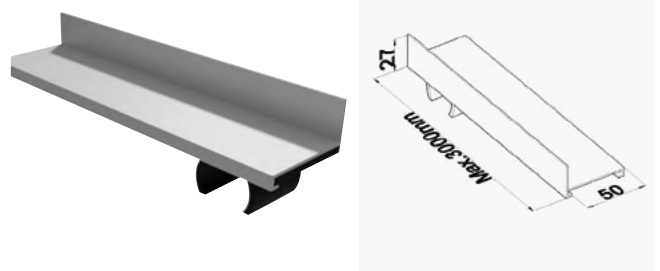

CV-MA13

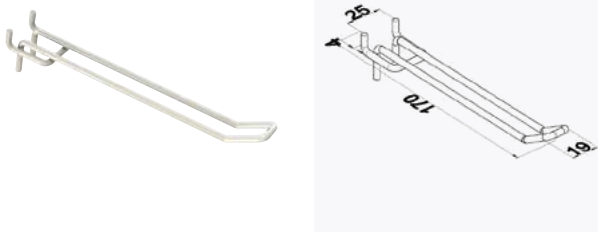

CV-MA14

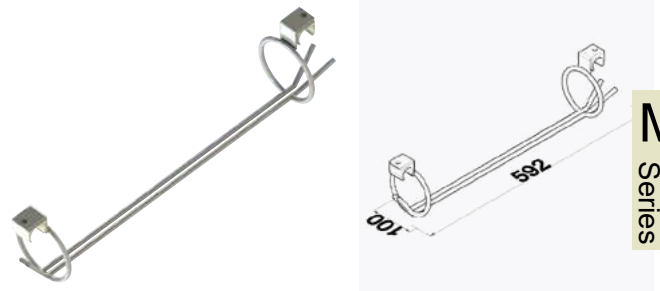

MA
Series

CV-MA15

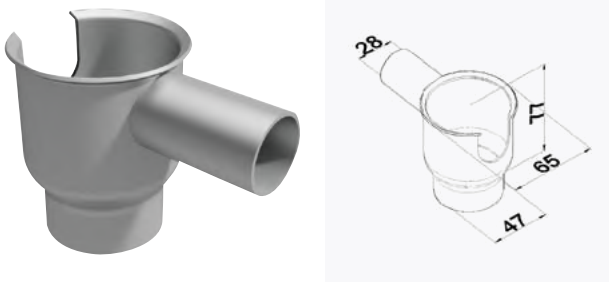

CV-MA16

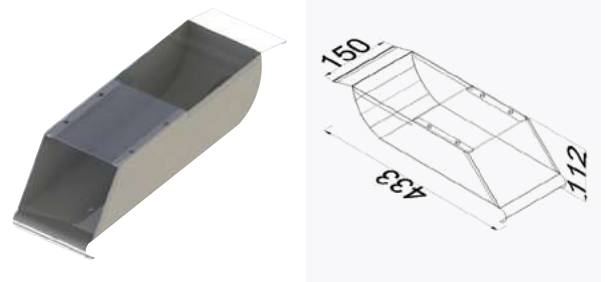

CV-MA17

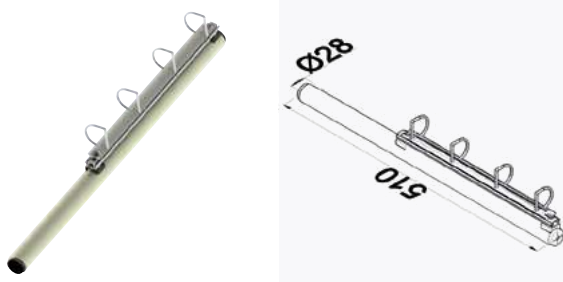

CV-MA18

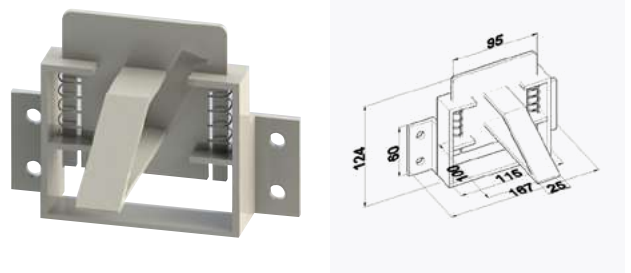

METAL ACCESSORIES

CV-MA19

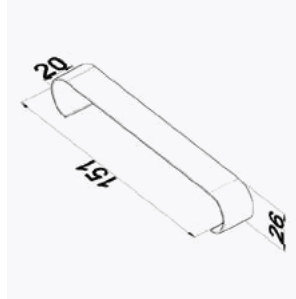

CV-MA20



CV-MA21

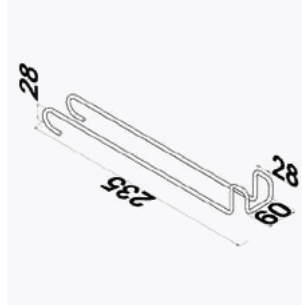

CV-MA22

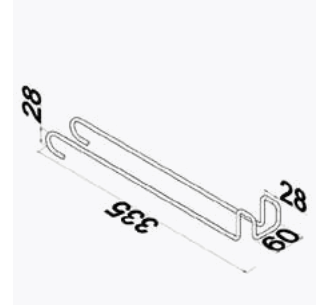
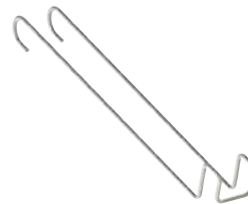

CV-MA23

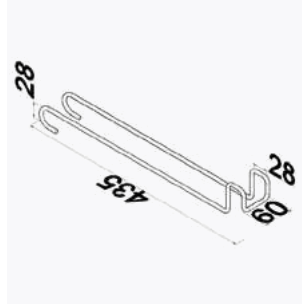

CV-MA24

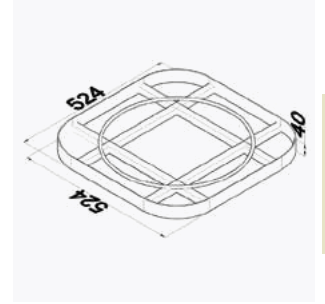
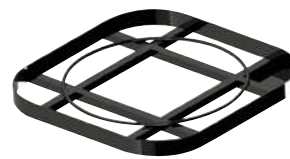

MA
Series

CV-MA25

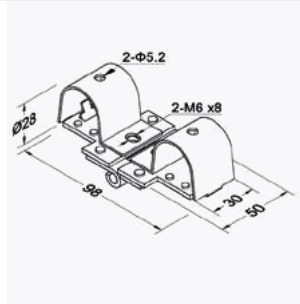

CV-MA26

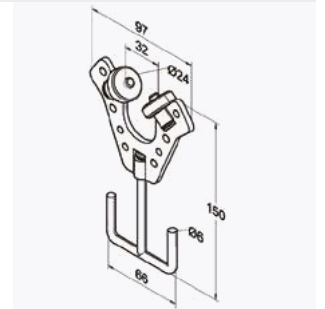

CV-MA27

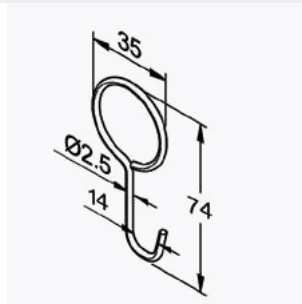

CV-MA28

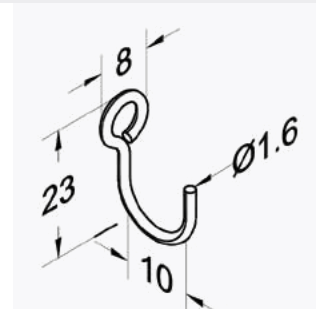

CV-MA29

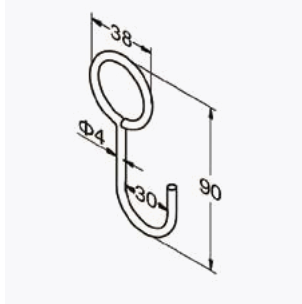

CV-MA30

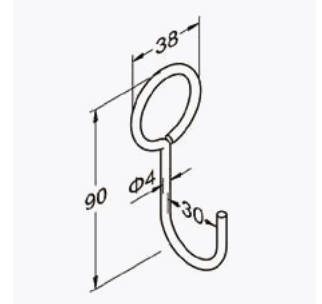

CV-MA31

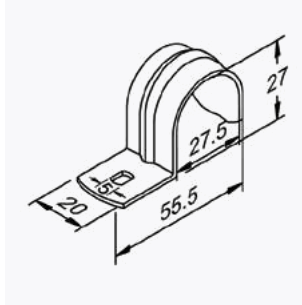

CV-MA32

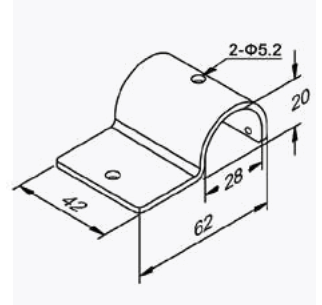

CV-MA33

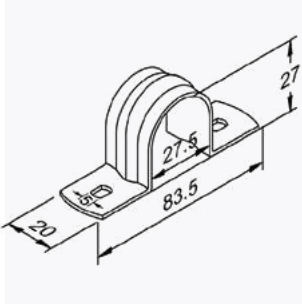
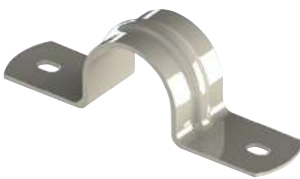

CV-MA34

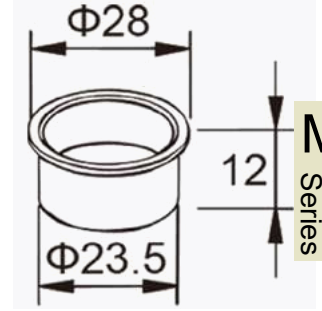

MA
Series

CV-MA35

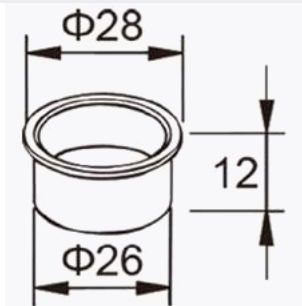

CV-MA36A

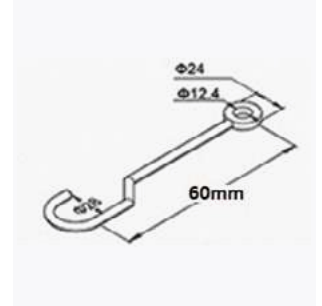

CV-MA36B

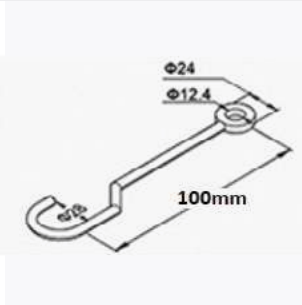
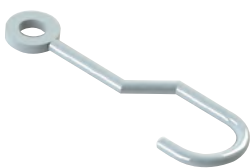

CV-MA36C

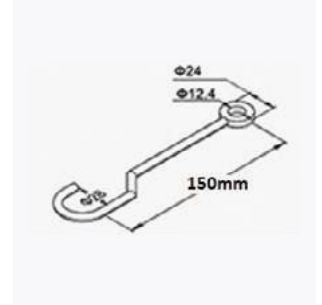

METAL ACCESSORIES

CV-MA36D

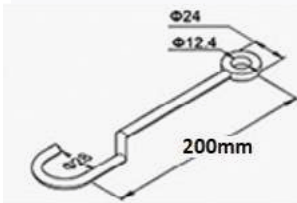

CV-MA37

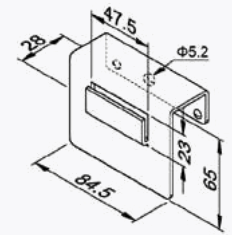
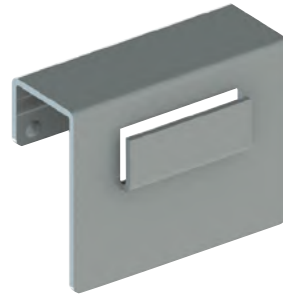

CV-MA38

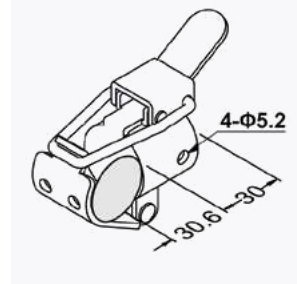

CV-MA39

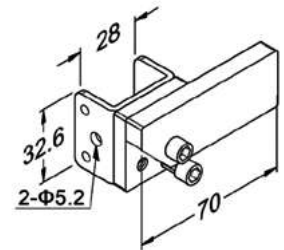

CV-MA40

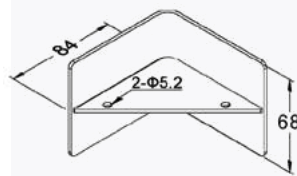
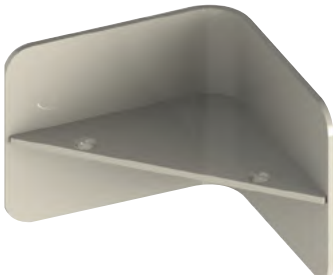

CV-MA41

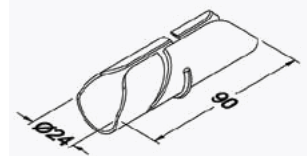
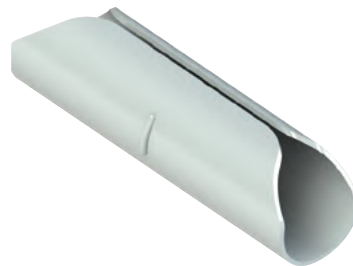

CV-MA42

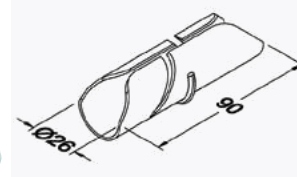
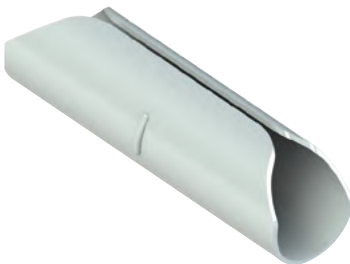

CV-MA43

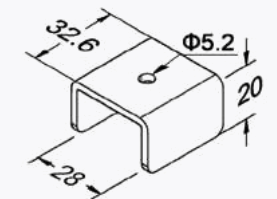
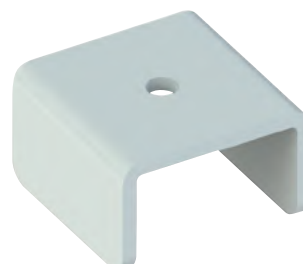

CV-MA44

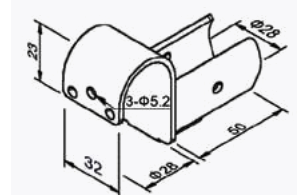

CV-MA45

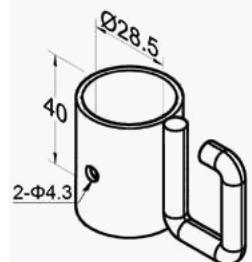

MA
Series

CV-MA46

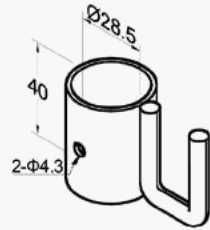

CV-MA47

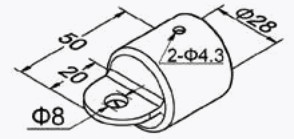

CV-MA48

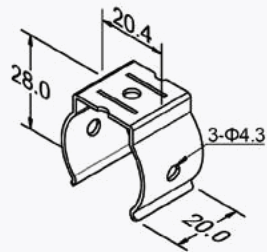

CV-MA49

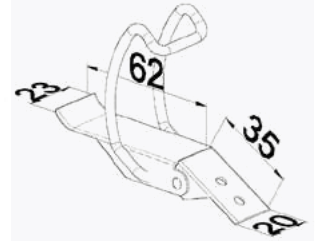

CV-MA50

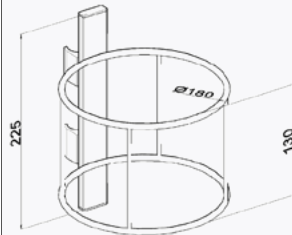
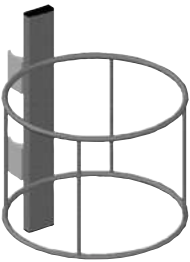



F Series FASTENERS





FASTENERS

CV-FB0625

M6 — L: 25mm



CV-FB-03-04-79 (for CV-PA61)

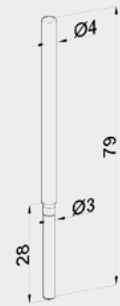

CV-FB0415



CV-FB0625



CV-FB0630



CV-FB0615



CV-FB0840



CV-FB0835



CV-FN06



CV-FN08



CV-FSF0416



CV-FSF0432



CV-FSB0416



CV-FSB0432



CV-FSW0310



CV-FSW0316



CV-FW04



CV-FW06



CV-FW08



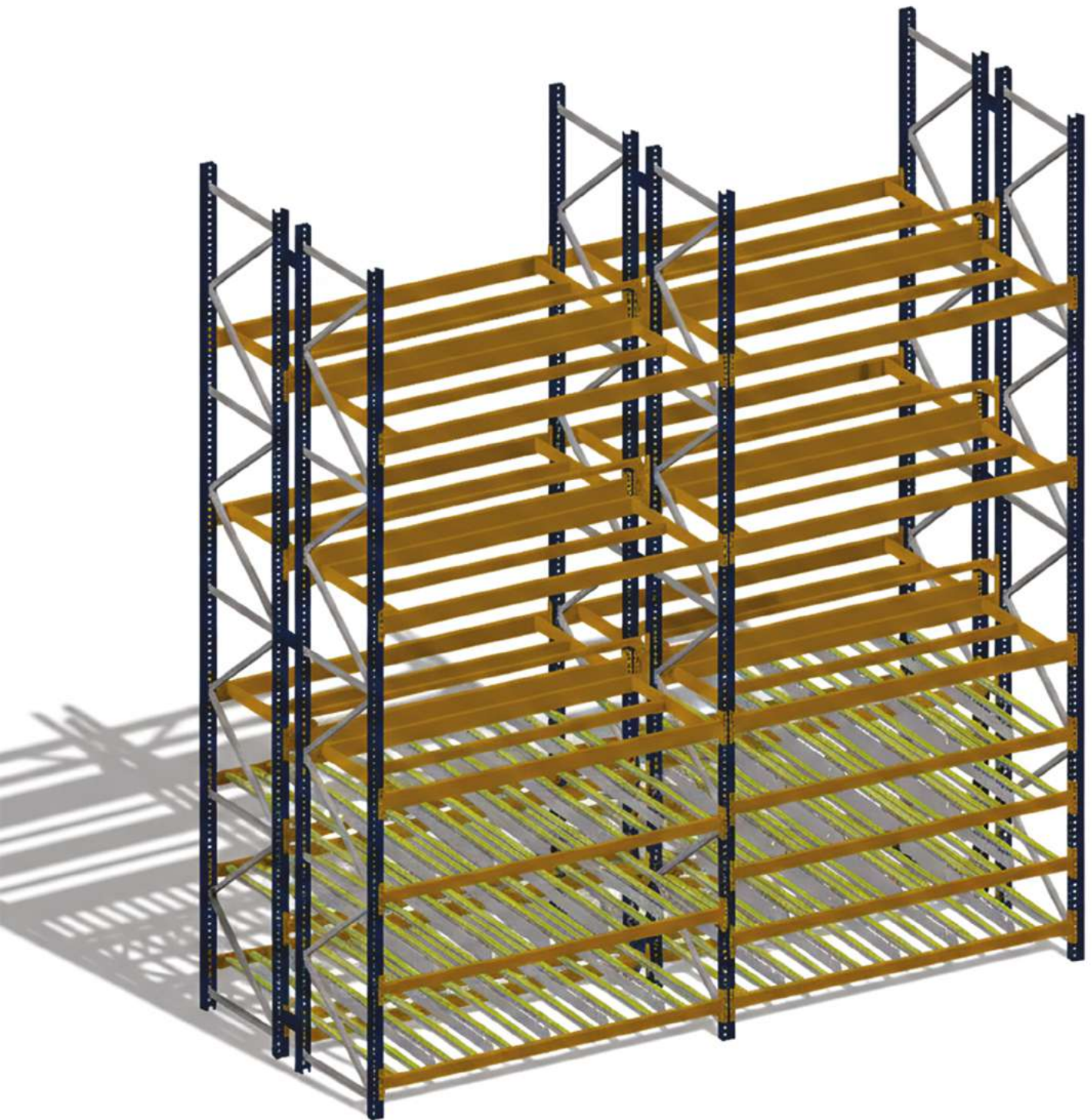

CASTERS & FEETS

CV-CT01



Part No.								
CV-CT01TT50B	20	10	201	-	69	2	35	50
CV-CT01TT75B	25	10	311	+	97	2	50	75

CV-CT02



Part No.									
CV-CT02BT75B	25	10	311	+	97	2	50	75	70
CV-CT02BT80B	32	1-2-3-4-5	869	S	106	2	75	80	70
CV-CT02BT100B	32	1-2-3-4-5	763	+	136	2,5	80	100	70
CV-CT02BT125B	32	1-2-3-4-5	921	+	160	2,5	90	125	70
CV-CT02BT150B	32	1-2-3-4-5	940	+	183	2,5	110	150	70
CV-CT02BT200B	32	1-2-3-4-5	1240	+	237	2,5	150	200	70

CV-CT02-ESD



Part No.									
CV-CT02TT50B-ESD	25	10	311	+	97	2	50	75	70
CV-CT02BT75B-ESD	32	1-2-3-4-5	869	S	106	2	75	80	70
CV-CT02BT100B-ESD	32	1-2-3-4-5	763	+	136	2,5	80	100	70
CV-CT02BT125B-ESD	32	1-2-3-4-5	921	+	160	2,5	90	125	70









CV-CT03



Part No.									
CV-CT03PT80B	30	85X100	763	-	106	2	90	80	60X80
CV-CT03PT100B	30	85X100	888	-	127	2	110	100	60x80
CV-CT03PT125B	37,5	85x100	1231	-	157	2	160	125	60x80









CV-CT04



Part No.	 (mm)	 (mm)	 (gr)	 (jant kapağı)	 (mm)	 (mm)	 (kg)	 (mm)	 (mm)
CV-CT04PT80S	30	85x100	650	-	106	2	90	80	60x80
CV-CT04PT100S	30	85x100	731	-	127	2	110	100	60x80
CV-CT04PT125S	30	85x100	1053	-	157	2	160	125	60x80









CV-CT05



Part No.	 (mm)	 (mm)	 (gr)	 (jant kapağı)	 (mm)	 (mm)	 (kg)	 (mm)	 (mm)
CV-CT05PT80R	30	85x100	337	-	106	1,5	90	80	60x80
CV-CT05PT100R	30	85x100	411	-	127	1,5	110	100	60x80
CV-CT05PT125R	37,5	85x100	791	-	157	2	160	125	60x80









CV-CT06



Part No.	 (mm)	 (mm)	 (gr)	 (jant kapağı)	 (mm)	 (mm)	 (kg)	 (mm)	 (mm)
CV-CT06PT100B	35	110x105	1410	+	138	3	150	100	80x80
CV-CT06PT125B	35	110x105	1630	+	161	3	180	125	80x80
CV-CT06PT150B	45	110x105	1855	+	187	3	210	150	80x80

CV-CT07











Part No.	 (mm)	 (mm)	 (gr)	 (jant kapağı)	 (mm)	 (mm)	 (kg)	 (mm)	 (mm)
CV-CT07PT100S	35	110x105	1010	+	138	3	150	100	80x80
CV-CT07PT125S	40	110x105	1230	+	161	3	180	125	80x80
CV-CT07PT150S	45	110x105	1455	+	187	3	210	150	80x80

CASTERS & FEETS

CV-CT08



Part No.	 (mm)	 (mm)	 (gr)	 (jant kapağı)	 (mm)	 (mm)	 (kg)	 (mm)	 (mm)
CV-CT08PT100R	35	120x79	765	+	138	3	150	100	96x48
CV-CT08PT125R	40	120x79	1070	+	161	3	180	125	96x48
CV-CT08PT150R	45	120x79	1340	+	187	3	210	150	96x48

CV-CT09

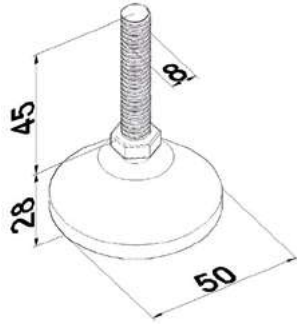



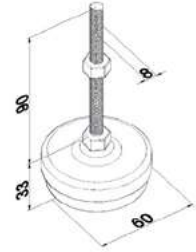



CV-CT10









CV-CT11



Part No.	 (mm)	 (mm)	 (mm)	 (kg)	 (mm)	 (mm)
	150	194	168	400	114x100	84x71

CV-CT12



Part No.	 (mm)	 (mm)	 (mm)	 (kg)	 (mm)	 (mm)
	80	210	170	400	120x120	85x85

CV-CT15

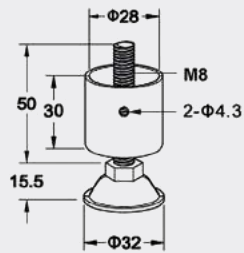

CV-CT21

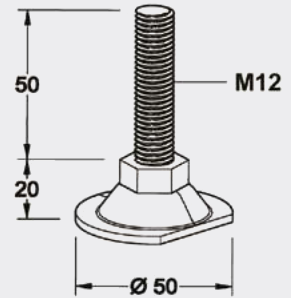

CV-CT23

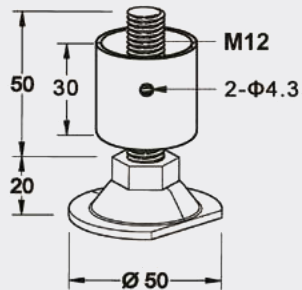

CV-CT24 - $\Phi 32$

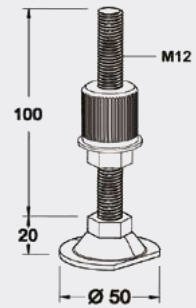

CV-CT25

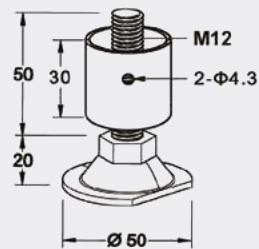

CV-CT27

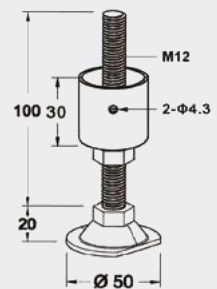

CV-CT28A

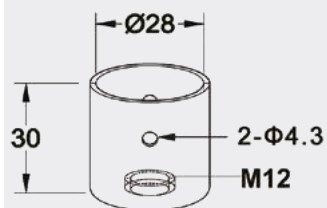

CV-CT28B

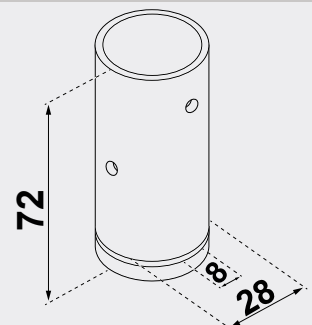

CASTERS & FEETS

CV-CT29

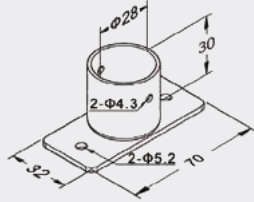

CV-CT30

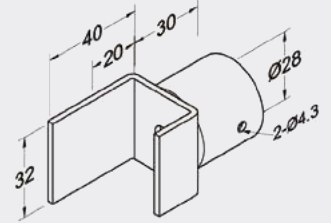
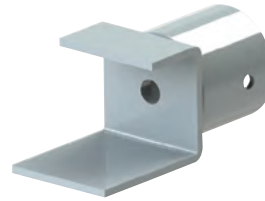

CV-CT31

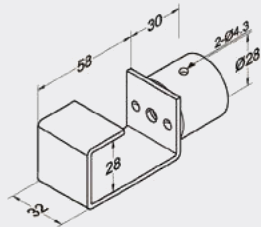
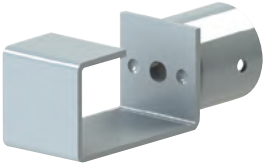

CV-CT33

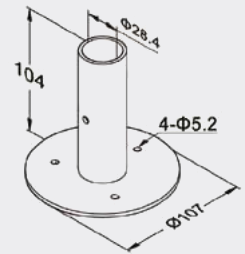

CV-CT34

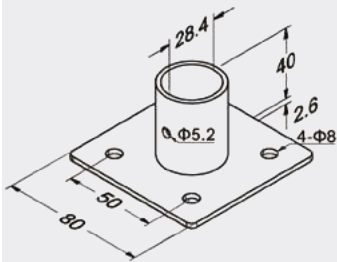
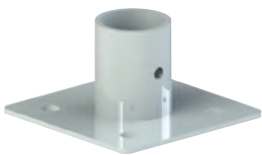

CV-CT35

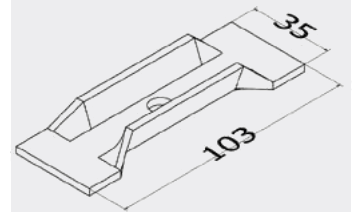

CV-CT36

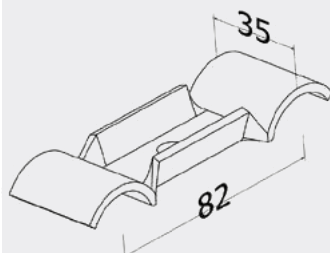

CV-CT37

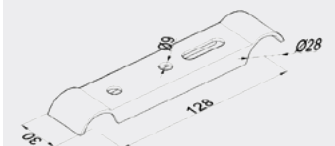

CT
Series

CV-CT38

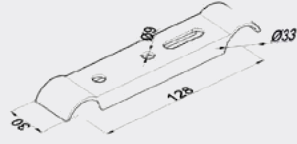

CV-CT39

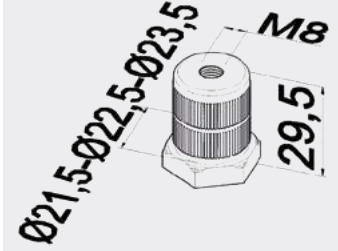

CV-CT40

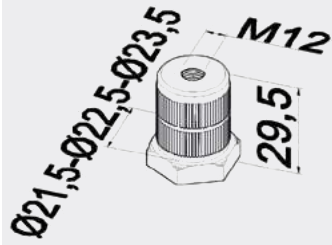

CV-CT41

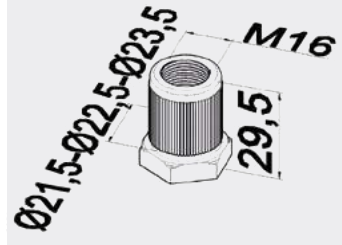

CV-CT42

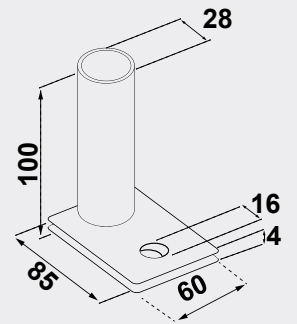

CV-CT43

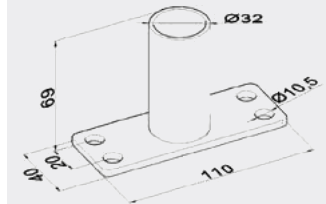
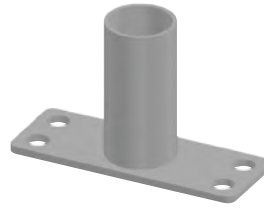

CV-CT44 (CV-CT02 için Soket Takımı)

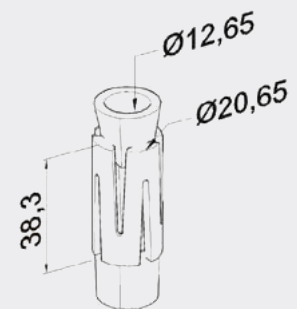



T Series TOOLS





TOOLS

CV-T01

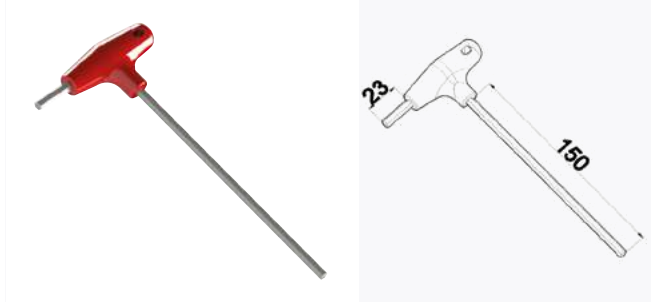

CV-T02

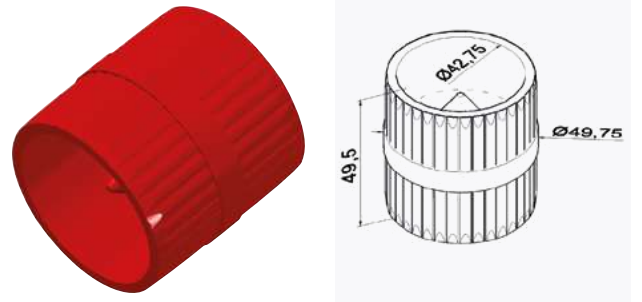

CV-T03



CV-T04

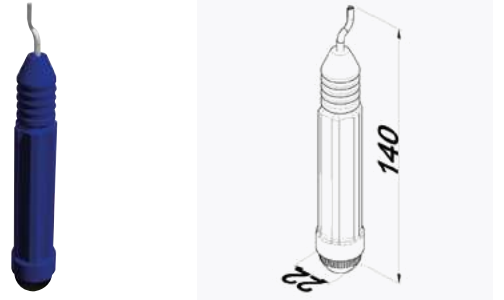

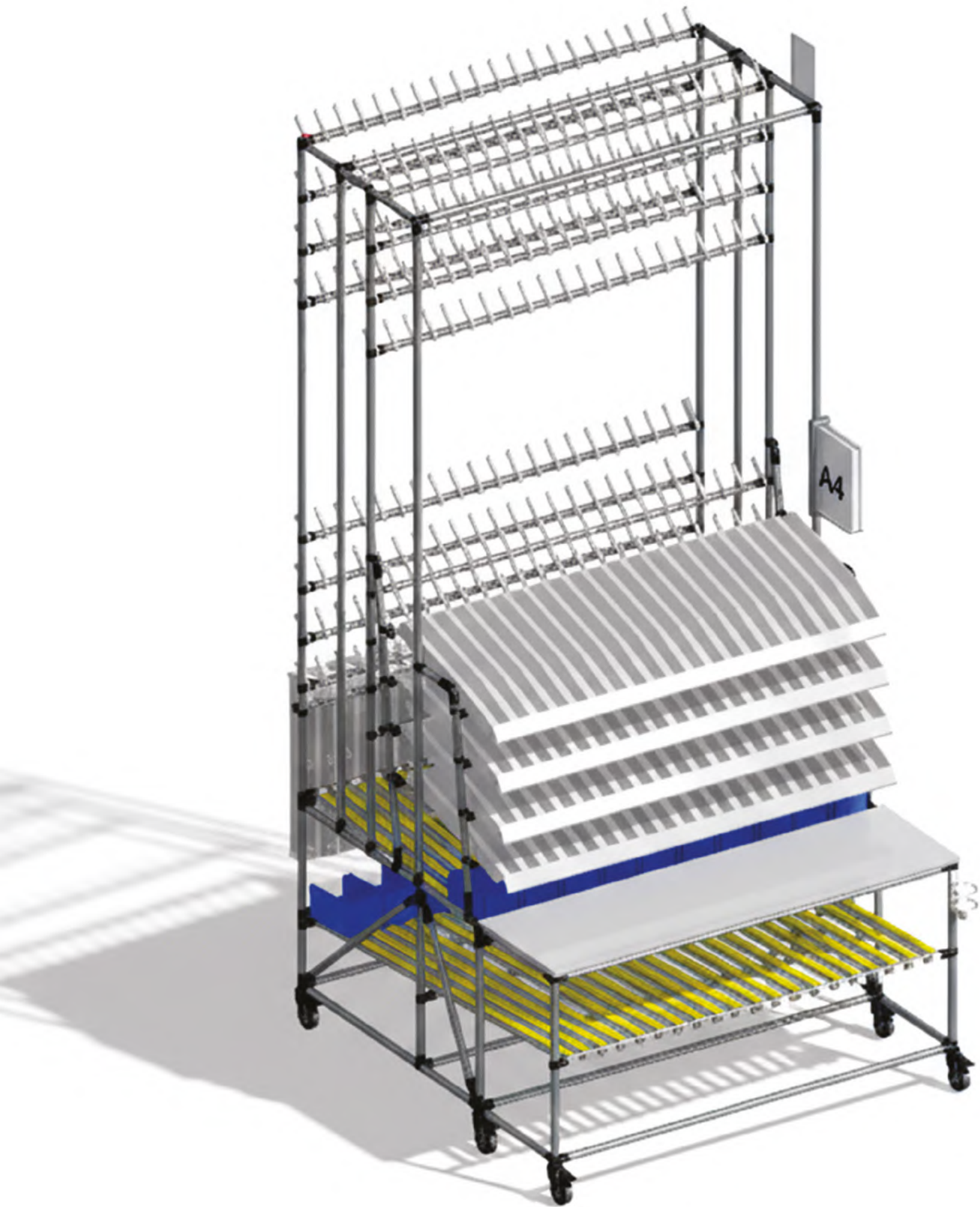

VE Series VISUAL EQUIPMENTS

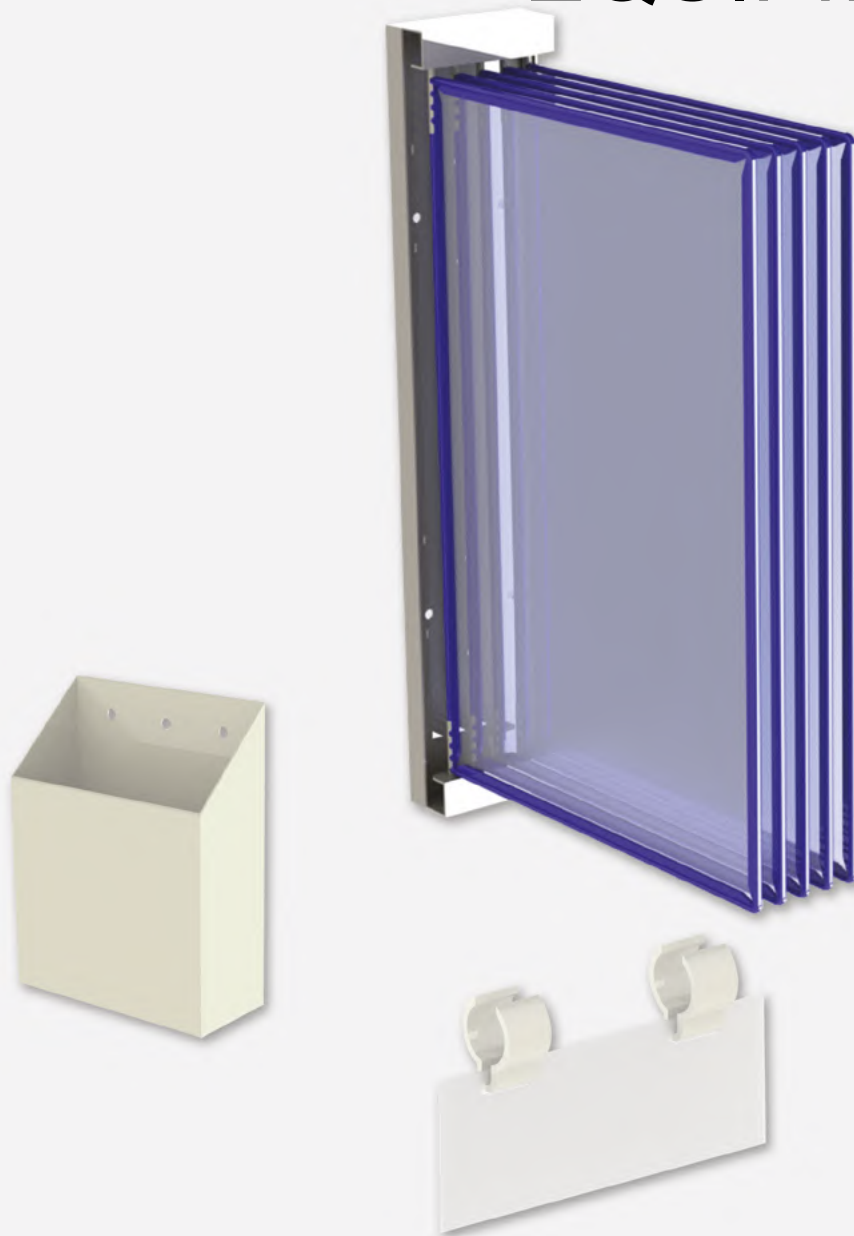

VISUAL EQUIPMENTS

CV-VE01

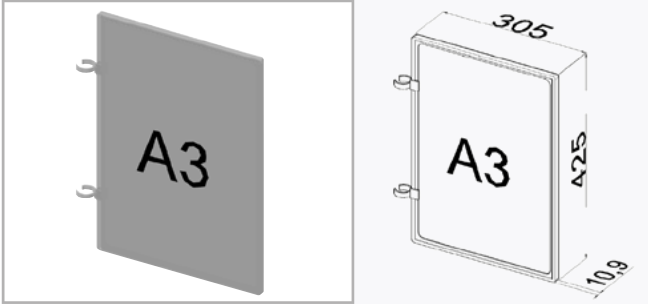

CV-VE01M / MIKNATISLI

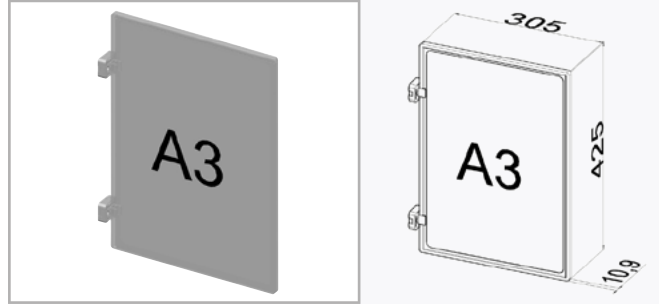

CV-VE02

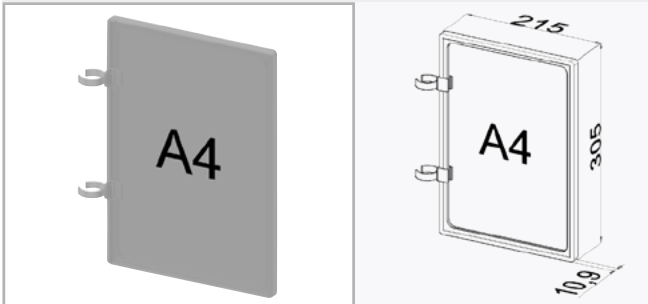

CV-VE02M / MIKNATISLI

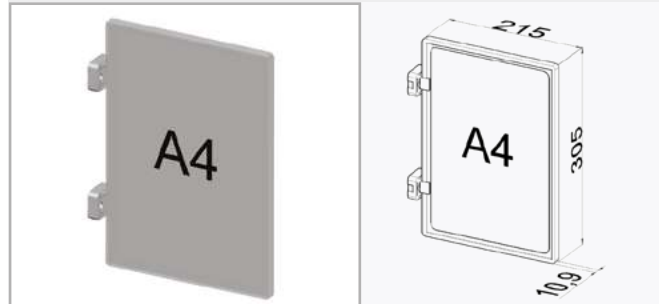

CV-VE03

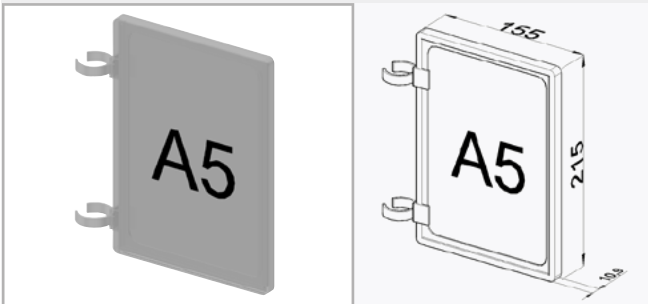

CV-VE03M / MIKNATISLI

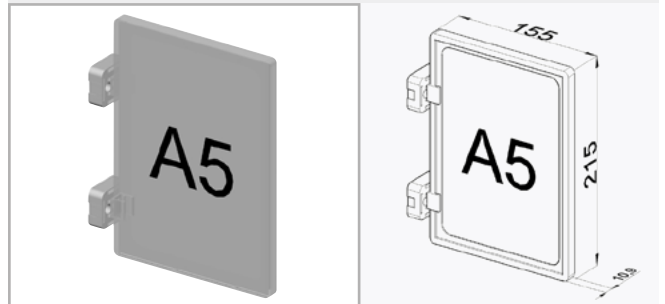

CV-VE04

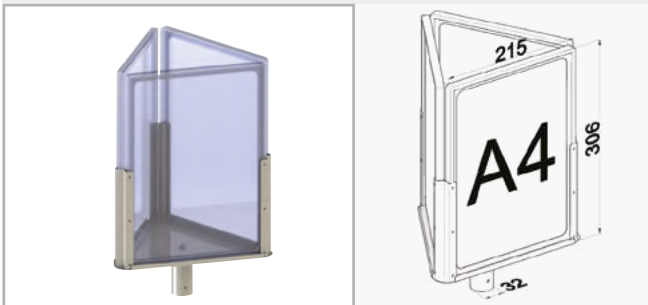

CV-VE05

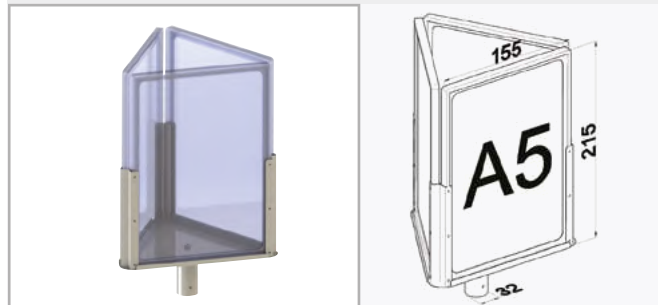

CV-VE06

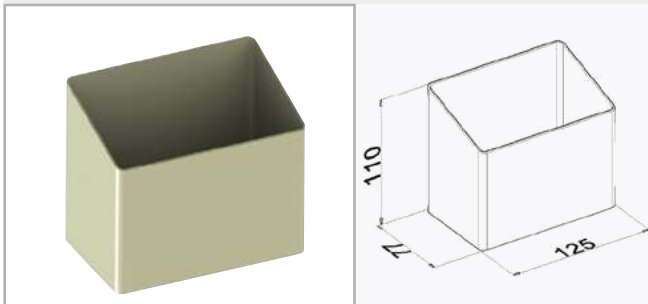

CV-VE07

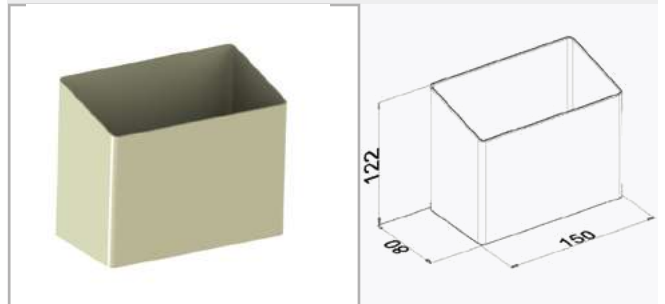

VE
Series

VISUAL EQUIPMENTS

CV-VE08

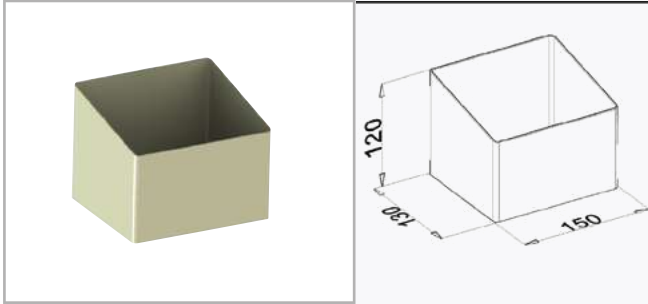

CV-VE09

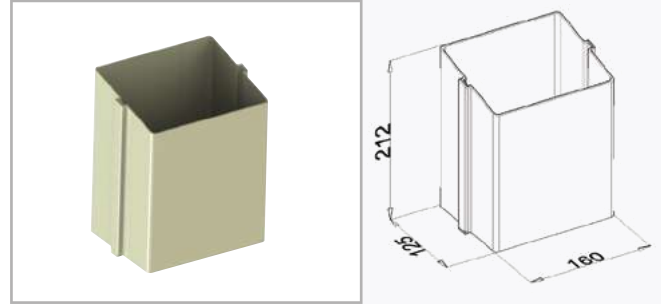

CV-VE10

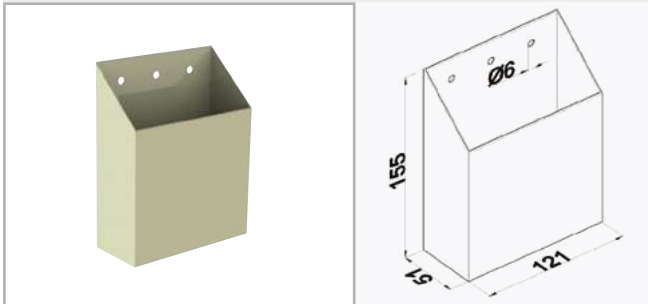

CV-VE11

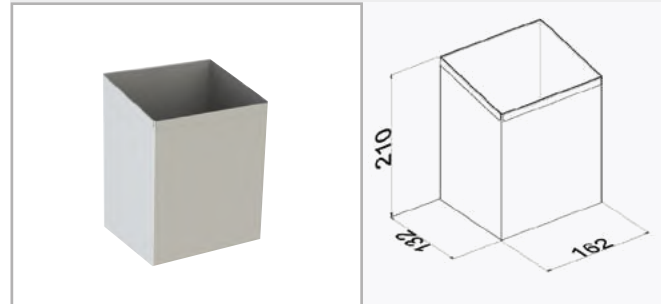

CV-VE12

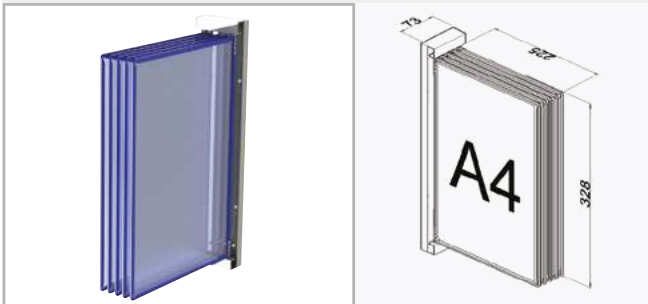

CV-VE12B

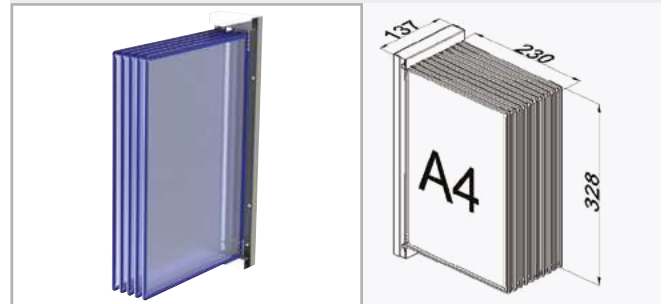

CV-VE13

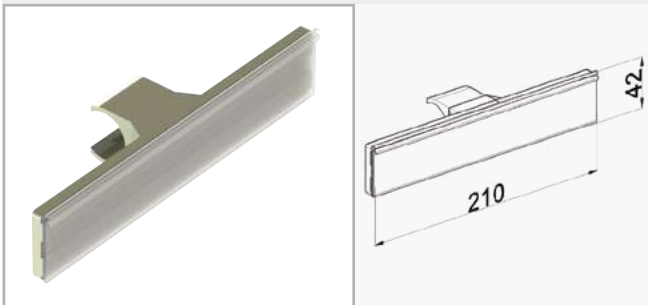

CV-VE14

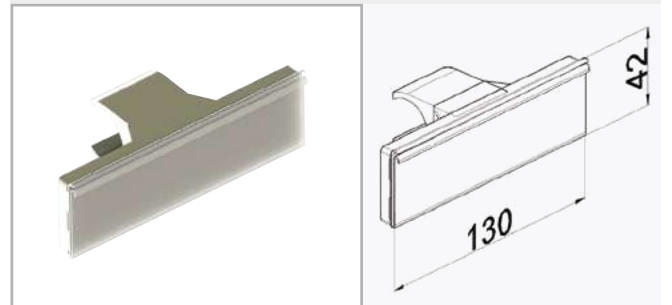

CV-VE15



CV-VE16

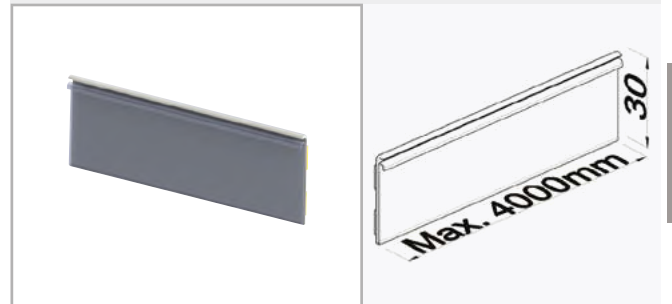

VE
Series

VISUAL EQUIPMENTS

CV-VE17

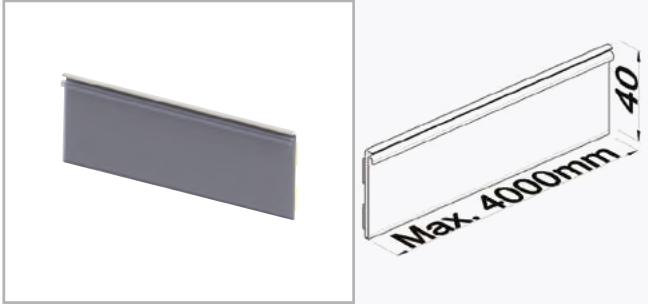

CV-VE18

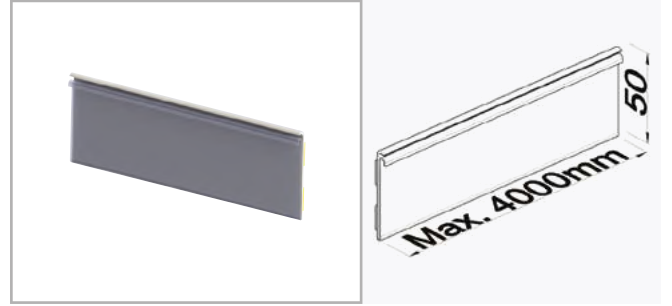

CV-VE19

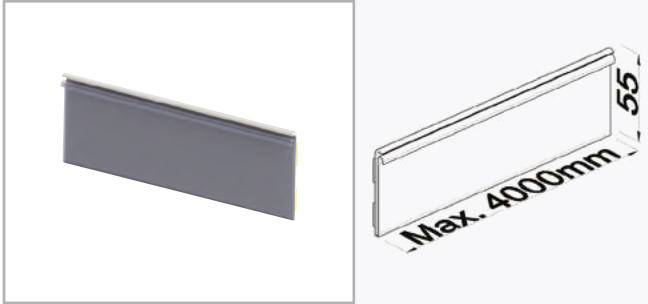

CV-VE20

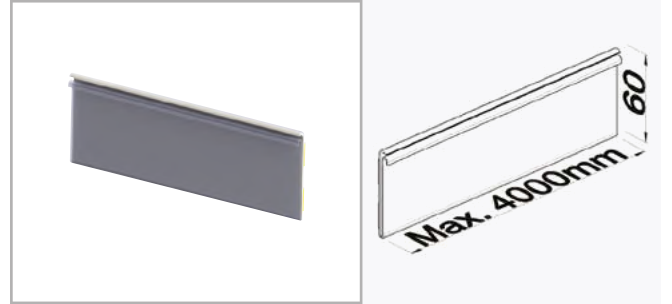

CV-VE21

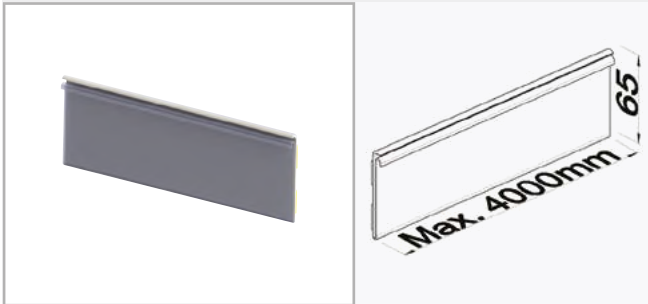

CV-VE22

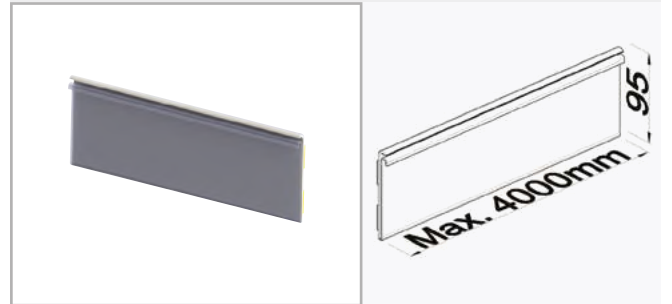

CV-VE23

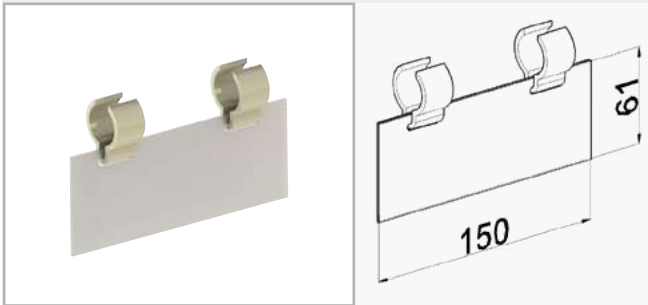

CV-VE24 - A4 MIKNATISLI ÇERÇEVE

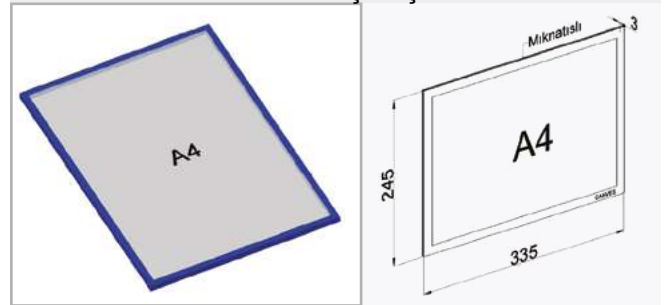

CV-VE25 - A3 MIKNATISLI ÇERÇEVE

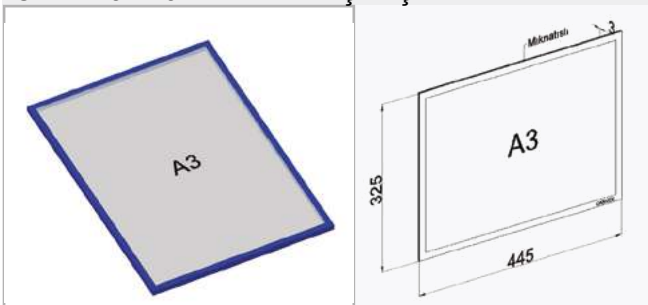

CV-VE26

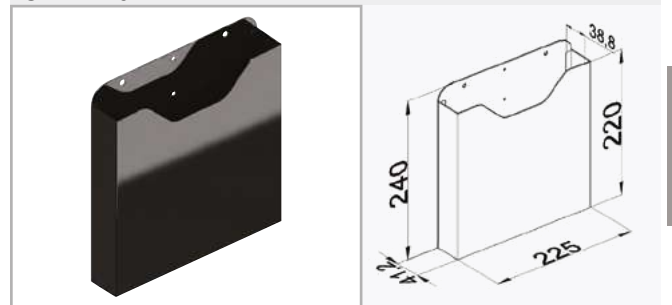

VE
Series

VISUAL EQUIPMENTS

CV-VE27

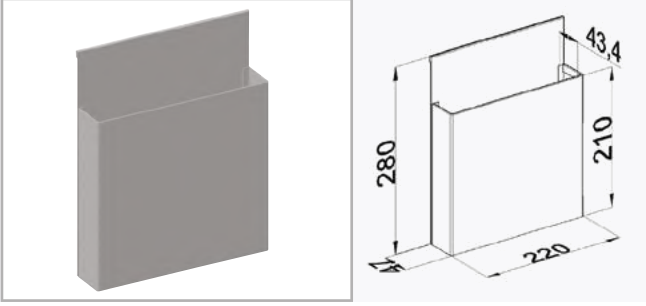

MDF Lam Renkli Yüzey



Kalınlık(mm):
8-16-18-36

Ham MDF Sade Yüzey



Kalınlık(mm):
8-16-18-36

Plywood Petek Desenli Yüzey - Kaymaz



Kalınlık(mm):
18-30

Petek Desen Dikap



Kalınlık(mm):
2

Polietilen Levha



Kalınlık(mm):
5-10

TT Series TRAILER EQUIPMENTS



TRAILER EQUIPMENTS

CV-TTB01

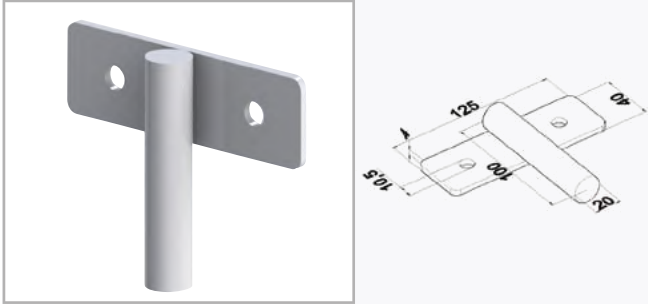

CV-TTB02

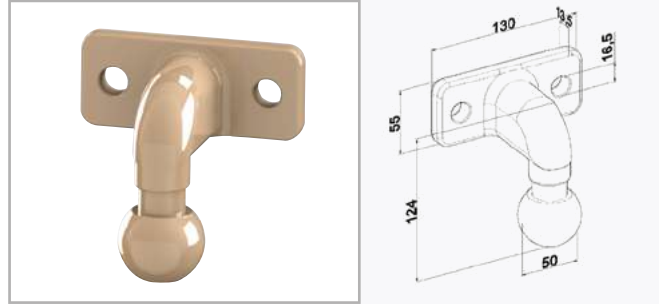

CV-TTF01

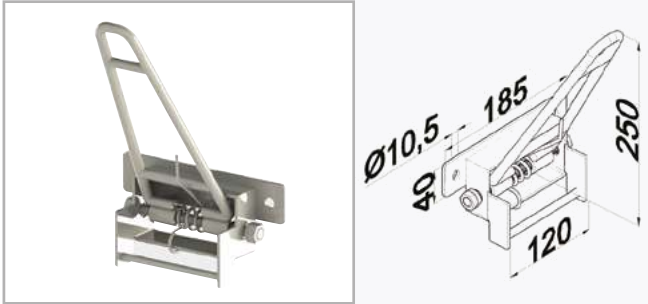

CV-TTF02



CV-TTF03A



CV-TTF03B / AĞIR TİP

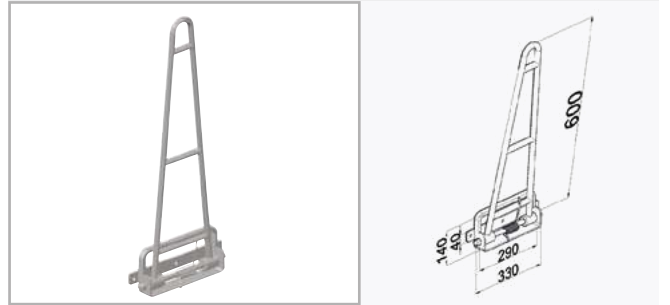

CV-TTF04A



CV-TTF04B / AĞIR TİP

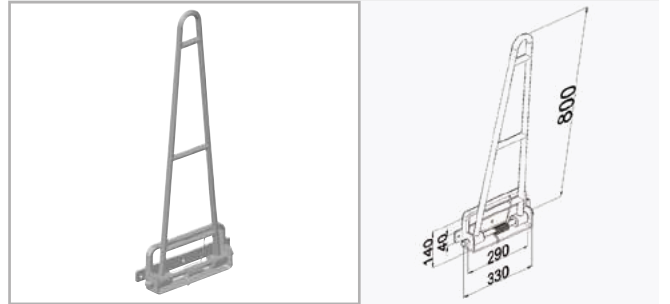

CV-TTF05



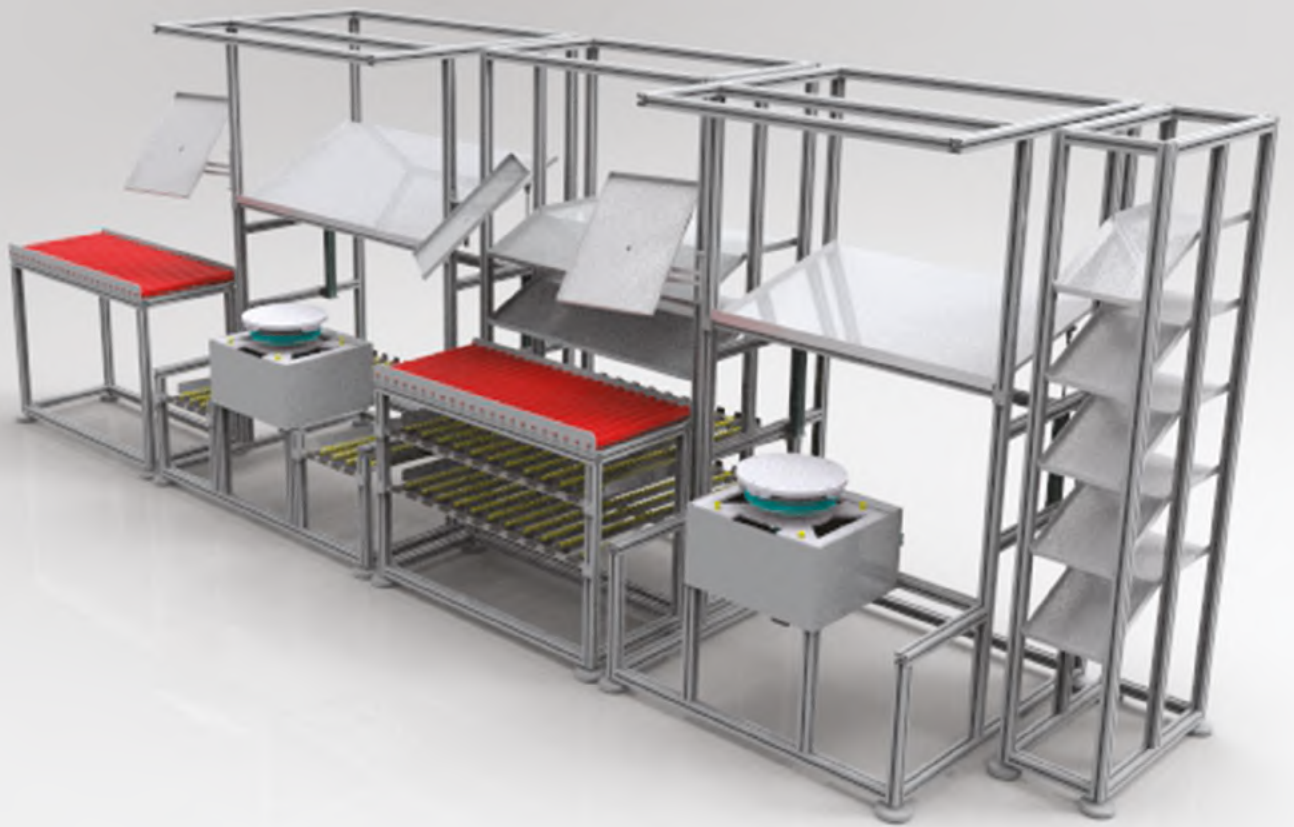

Turkiye (Main)

Address: Aşağı Çobanisa Çobanisa Mahallesi
Bağlar Caddesi No:18 Şehzadeler / Manisa

Tel: +90 236 313 3611

E-mail: info@canvesmakina.com

Website: www.canvesmakina.com

Italy

Address: Via Alessandro Volta 1/A,
35030 Rubano (PD), Italy

Tel: +39 347 310 80 43

E-mail: info@canvesgruppo.it

Website: www.canvesgruppo.it